

ROHS

客户图

| | | |
|------------|----------------------|------------|
| 目錄 MAPX | 变更内容 MODIFICATION | 日期 DATE |
| A0 | NEW | 09-10-20 |

PCB板厚建议1.3~1.6MM

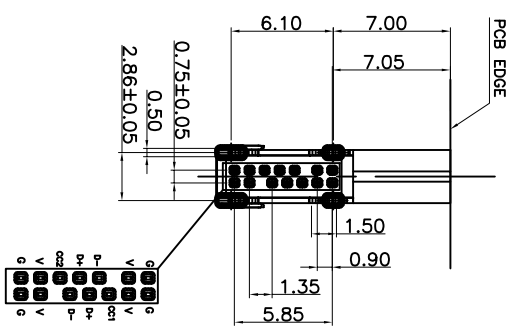
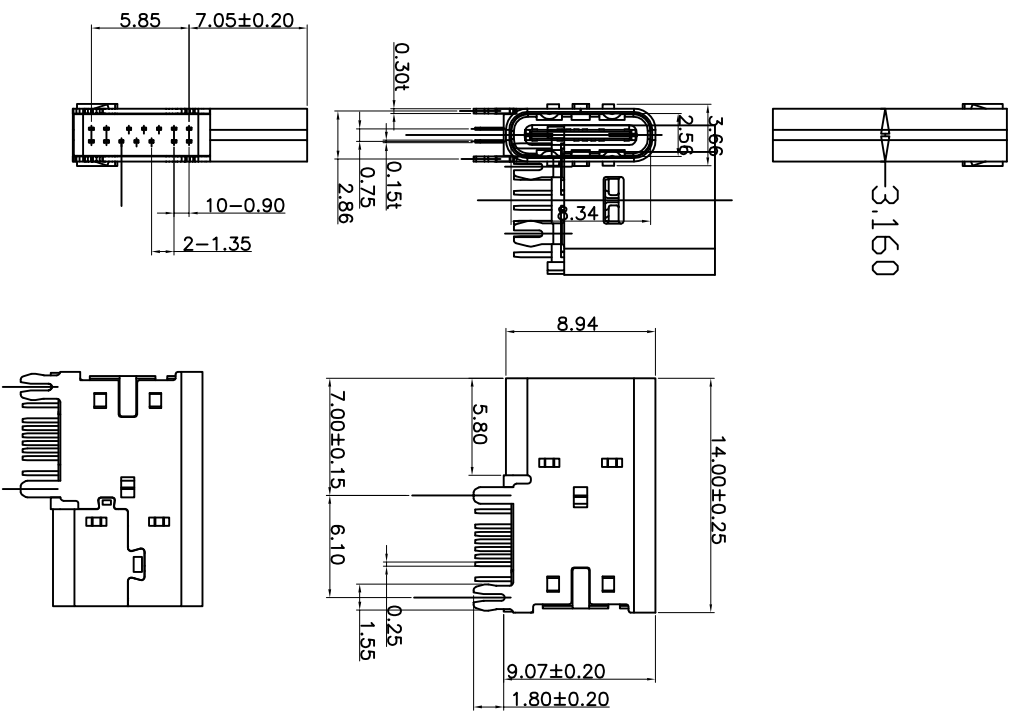

RECOMMENDED - P.C.B. LAYOUT TOLERANCE UNSPECIFIED ±0.05mm

| | | | |
|-----|-------------|-----|-------------|
| A1 | GND | B12 | GND |
| A4 | VBUS | B9 | VBUS |
| A5 | CC1 | B7 | DN2 |
| A6 | DP1 | B6 | DP2 |
| A7 | DN1 | B5 | CC2 |
| A9 | VBUS | B4 | VBUS |
| A12 | GND | B1 | GND |
| PIN | SIGNAL NAME | PIN | SIGNAL NAME |

- SPECIFICATIONS:
- MECHANICAL :
 - INSERTION FORCE : 5N~20N
 - WITHDRAWAL FORCE : 8N~20N
AFTER 10,000 CYCLES MATING: 2N MIN.
 - ELECTRICAL :
 - CONTACT CURRENT RATING: 3A .
 - VOLTAGE RATING : 30V AC (rms)
 - WITHSTANDING VOLTAGE: 100 VAC FOR 1 MINUTE.
INSULATION RESISTANCE: 100 MEGOHMS MIN.
 - CONTACT RESISTANCE: 40 MILLIOHMS MAX.
 - ENVIRONMENTAL :
 - OPERATING TEMPERATURE: -25° C TO +85° C

| | | | | |
|-----|-----------------|-----------------|-------|-------------|
| NO. | DESCRIPTION | MATERIAL | COLOR | REMARK |
| 1 | SHELL | STAINLESS STEEL | — | Ni Plated |
| 2 | TYPE C TERMINAL | COPPER ALLOY | — | Gold Plated |
| 3 | CENTER PIECE | STAINLESS STEEL | — | N0 Plated |
| 4 | TYPE C HD | HIGH TEMP | BLACK | UL 94V-0 |
| 5 | | | | |
| 6 | | | | |
| 7 | | | | |

产品图
PRODUCT CHART DWG

深圳市鑫风雷电子有限公司

| | | | | | | | |
|-------------------------------------|-------|-------------|-------|---------------|------------|--------------------------|--------------------|
| 公差一览表 TOLERANCE UNLESS OTHERWISE | | 单位 UNITS | MM | 制图 DRAWING | 王冠 | 产品料号 PRODUCT PART NO. | XFLJ008-UCAF002-X |
| X | ±0.30 | X' | ±5' | 审核 CHECK | 雷永健 | 产品名称 PRODUCT NO. | TYPE C母座侧插14P针长1.7 |
| .XX | ±0.25 | .XX' | ±2' | 批准 APPRO | 雷永健 | 角法 VIEW | ⊕ |
| .XXX | ±0.30 | .XXX' | ±1' | 日期 DATE | 2009/10/20 | 版本 VER | A0 |
| | ±0.15 | | ±0.5' | | | | |