

# RoHS 客户图

目錄 MAPX A0	變更內容 MODIFICATION NEW	日期 DATE 09-10-20
------------------	-----------------------------	------------------------

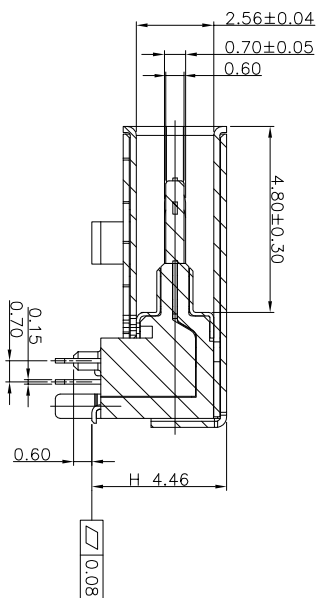

Section A-A  
Scale 1:1

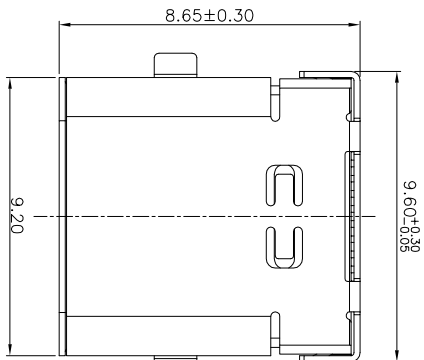
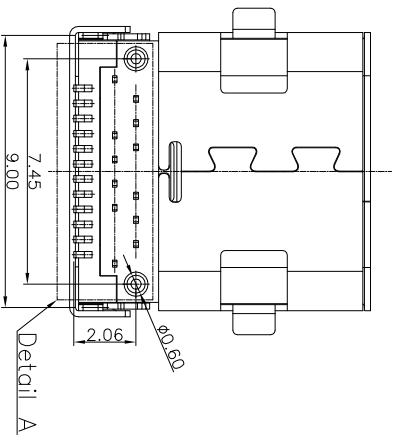
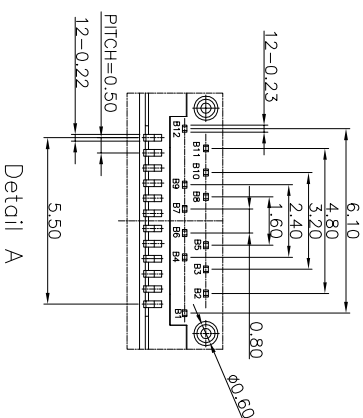
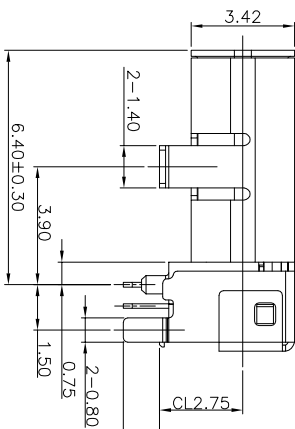
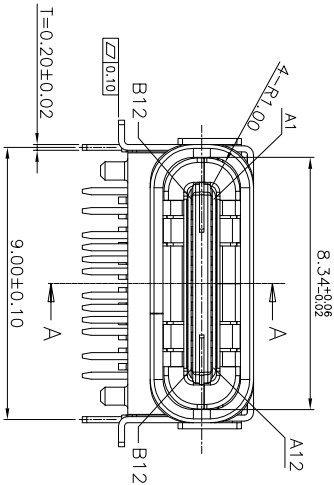

NOTES:

1. MATERIAL:  
MOLDING: LCP UL94 V-0  
CONTACT: COPPER ALLOY.  
GOLD PLATED Min ON CONTACT AREA: 100u"  
Min TIN (LEAD FREE) ON SOLDER AREA,  
SHELL: SUS304-H,T=0.20±0.03mm  
50u" NICKEL PLATING OVER ALL.  
SHLD: SUS304-H,T=0.12±0.03mm
2. MECHANICAL:  
INSERTION: 5~20N.  
EXTRACTION: 8~20N AFTER TEST.  
DURABILITY: 10000 CYCLES
3. ELECTRICAL:  
CURRENT: 5A FOR VBUS;  
1.25A FOR GND PIN.  
0.25A FOR OTHER.  
VOLTAGE: 20 V MAX  
WITHSTANDING VOLTAGE: 100V AC R.M.S.  
CONTACT RESISTANCE: 40mΩ MAX.  
INSULATION RESISTANCE: 100MΩ MIN.
4. ENVIRONMENTAL  
TEMPERATURE RANGE -55°C ~ +85°C

## 产品图

## 深圳市鑫风雷电子有限公司

公差一览表 TOLERANCE UNLESS OTHERWISE SPECIFIED		单位 UNITS	MM	制图 DRAWING	王冠	产品料号 PRODUCT PART NO.	00501-UCAF015-A
X	±0.30	X'	±5'	审核 CHKD	雷永健	产品名称 PRODUCT NO.	TYPE: C09 规格: 上双壳 前置后插 29P L=38.65 插距=4.46
XX	±0.25	X''	±2'	核准 APPD	雷永健	角法 VIEW	
XXX	±0.15	XXX'	±0.5'	日期 DATE	2009/10/20	版本 VER	A0

# ROHS 客户图

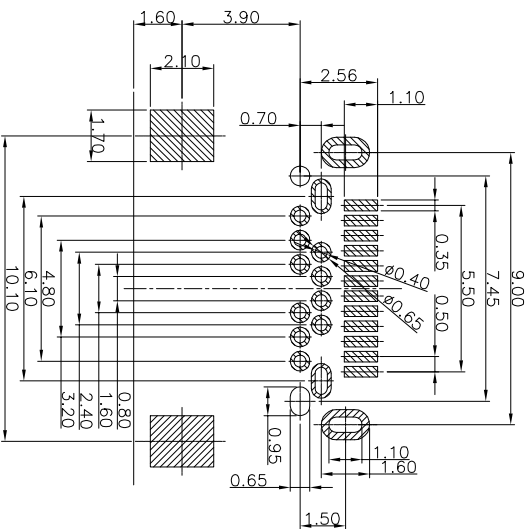
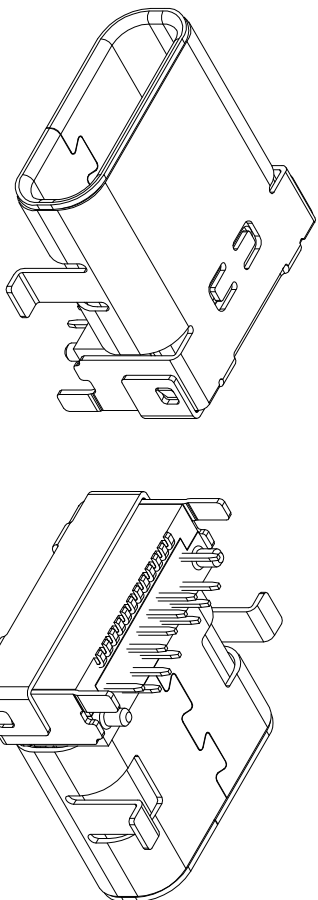

RECOMMEND P.C.B LAYOUT(COMPONENT SIDE)  
TOLERANCE FOR PCB LAYOUT IS ± 0.05

目錄 MAPX A0	變更內容 MODIFICATION NEW	日期 DATE 09-10-20
------------------	-----------------------------	------------------------

USB TYPE-C FULL-SPEED RECEPTACLE INTERFACE PIN ASSIGNMENTS

PIN	Signal Name	Description	PIN	Signal Name	Description
A1	GND	Ground return	B12	GND	Ground return
A2	SSTXp1	Positive half of first SuperSpeed TX differential pair	B11	SSRXp1	Positive half of first SuperSpeed RX differential pair
A3	SSTXn1	Negative half of first SuperSpeed TX differential pair	B10	SSRXn1	Negative half of first SuperSpeed RX differential pair
A4	Vbus	Bus Power	B9	Vbus	Bus Power
A5	CC1	Configuration Channel	B8	SRU2	Sideband Use (SRU)
A6	Dp1	Positive half of the USB 2.0 differential pair-Position 1	B7	Dm2	Negative half of the USB 2.0 differential pair-Position 2
A7	Dn1	Negative half of the USB 2.0 differential pair-Position 1	B6	Dp2	Positive half of the USB 2.0 differential pair-Position 2
A8	SBU1	Sideband User (SBU)	B5	CC2	Configuration Channel
A9	Vbus	Bus Power	B4	Vbus	Bus Power
A10	SSRXn2	Negative half of second SuperSpeed RX differential pair	B3	SSRXn2	Negative half of second SuperSpeed TX differential pair
A11	SSRXp2	Positive half of second SuperSpeed RX differential pair	B2	SSRXp2	Positive half of second SuperSpeed TX differential pair
A12	GND	Ground return	B1	GND	Ground return

## 产品图

### 公差一览表

TOLERANCE UNLESS OTHERWISE SPECIFIED	公差一览表	UNIT	比例	日期	制图	审核	批准	产品料号	产品名称	角法	版本
X	±0.30	X'	±5'	2009/10/20	王冠	雷永健	雷永健	00501-UCAF015-A	TYPE C母座板上双壳前置后插24P L=36.65插距=4.46	第三角法	A0
X	±0.25	X'	±2'								
XX	±0.30	XX'	±1'								
XXX	±0.15	XXX'	±0.5'								

# RoHS 客户图

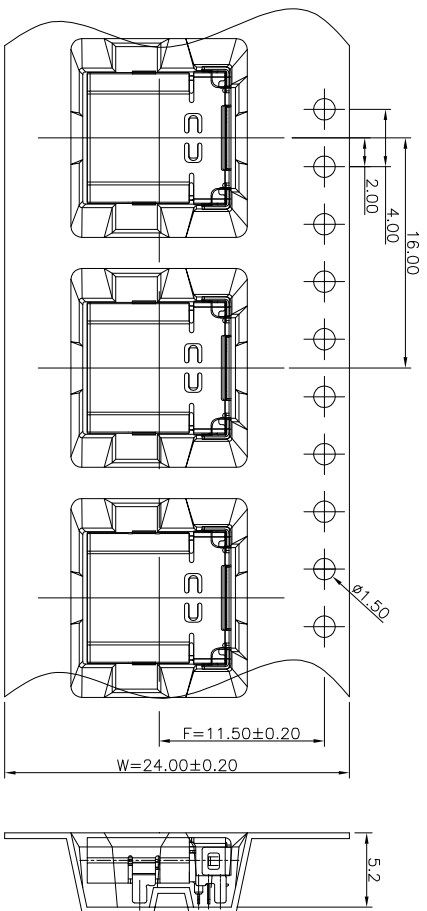
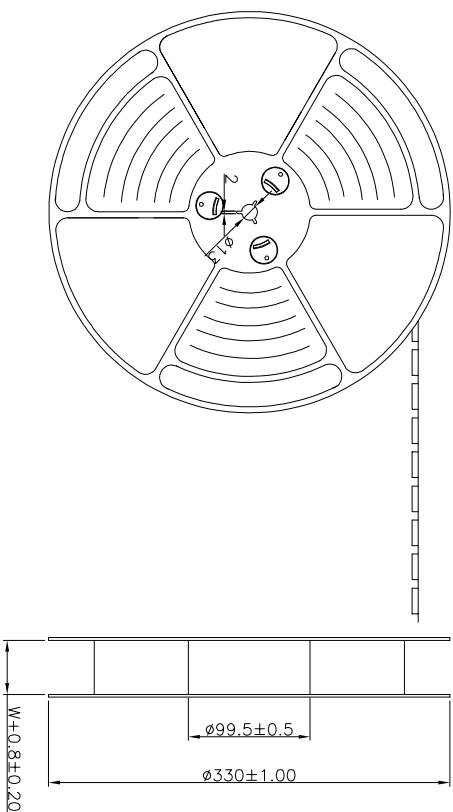

### NOTES

1. 带子引导长度  
LEAD TAPE LENGTH  
出料方向  
PULL OUT DIRECTION

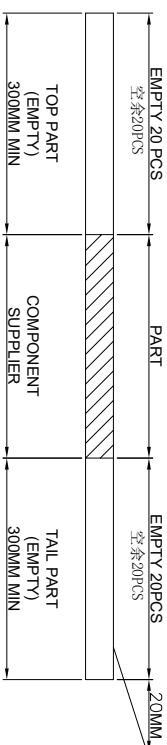

2. 出货运输过程中一定注意:  
THIS REQUIREMENT SHOULD BE APPLIED AT SHIPMENT:  
卷带在运输过程中不能散开  
PEELING OFF SHOULD NOT BE ALLOWED DURING TRANSPORTATION

目錄 MAPX	变更内容 MODIFICATION	日期 DATE
A0	NEW	09-10-20

## 产品图

PRODUCT CHART DWG  
深圳市鑫风雷电子有限公司

公差一览表 TOLERANCE UNLESS OTHERWISE		单位 UNITS	MM	制图 DRAWING	王冠 WANG GUAN	产品料号 PRODUCT PART NO.
X	±0.30	X'	±5°	审核 CHECK	雷永健 LEI YONGJIAN	00501-UCAF015-A
X	±0.25	X'	±2°	核准 APPROVE	雷永健 LEI YONGJIAN	TYPE: C09 屏板上双孔前置后插24P 1-3# 65抽高=4.46
XX	±0.30	XX'	±1°	日期 DATE		
XXX	±0.15	XXX'	±0.5°			

# RoHS 客户图

目錄 MAPX	變更內容 MODIFICATION	日期 DATE
A0	NEW	09-10-20

at small positioning hole of the carrier tape side).  
標簽黏貼處 (朝捲裝包材的小定位孔一側)  
Location of label sticking (label)

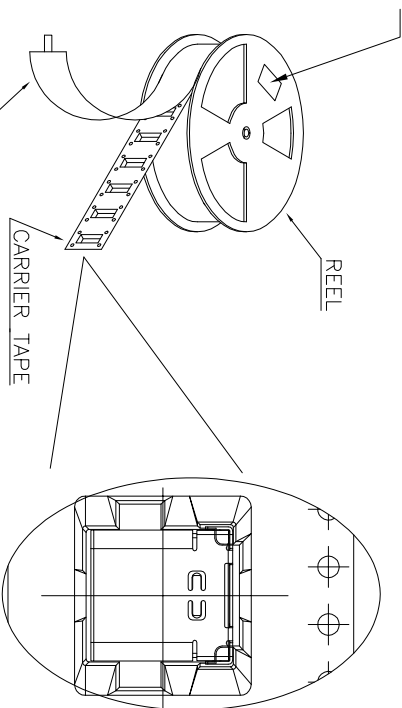
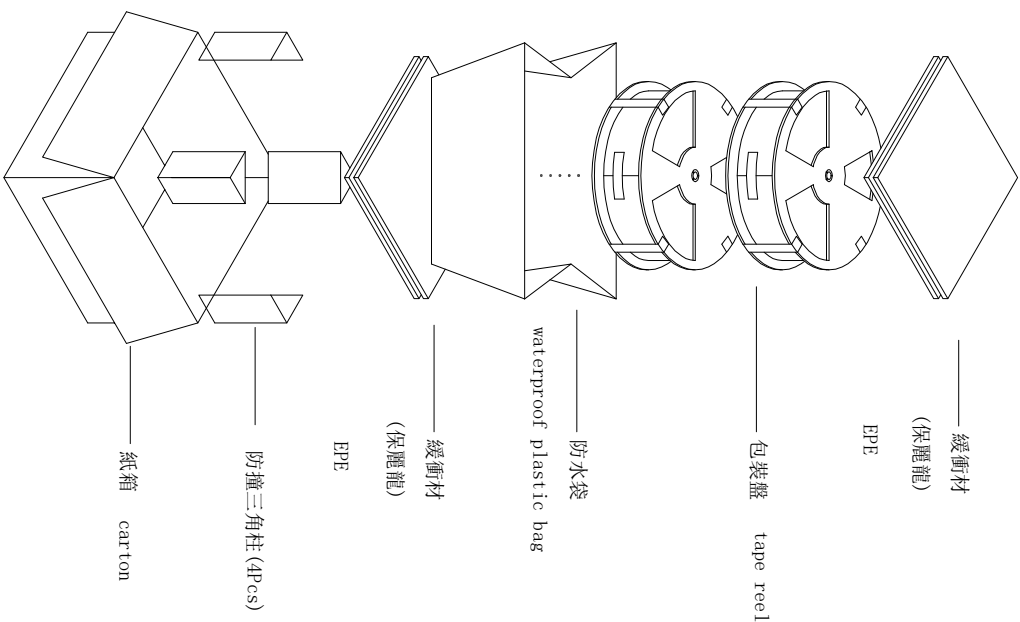

NOTE:

1. 每捲包裝數量及每箱裝箱數量如左下表格  
Packing qty of each reel & carton as below table shown.
2. 以上膠帶覆蓋下包裝帶經包裝機自粘包裝  
Use cover tape to cover and hot melt machine to seal up.
3. 每個紙箱放2個珍珠棉  
Every carton use 2pcs EPE.
4. 將裝滿產品的卷盤放入紙箱並以膠帶封口  
Put reels in the carton and use adhesive tape to seal up.

## 產品圖

PRODUCT CHART DWG

## 深圳市鑫風雷電子有限公司

公差一覽表 TOLERANCE UNLESS OTHERWISE		單位 UNITS	MM	制圖 DRAWING	王冠 CORONA	產品料號 PRODUCT PART NO.
X	±0.30	X'	±5'	審核 CHECK	雷永健 LEI YONGJIAN	00501-UCAF015-A
.X	±0.25	.X'	±2'	核准 APPROVE	雷永健 LEI YONGJIAN	TYPE: C09 標板: 上: 3次 前: 推 后: 424P L=36 65抽高=4.46
.XX	±0.30	.XX'	±1'	日期 DATE	2009/10/20	角法 VIEW
.XXX	±0.15	.XXX'	±0.5'			

包裝容量 (PACKING CAPACITY)	重量 (Kg)
PCS/REEL	N.W./PCS
REELS/CARTON	N.W./BOX
PCS/CARTON	G.W./BOX
8	0.704
5200	