

# ROHS 客户图

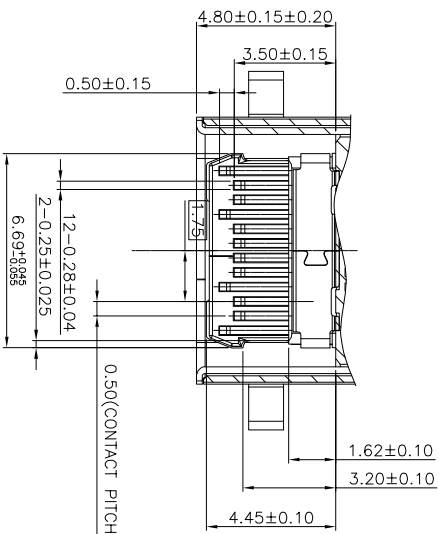
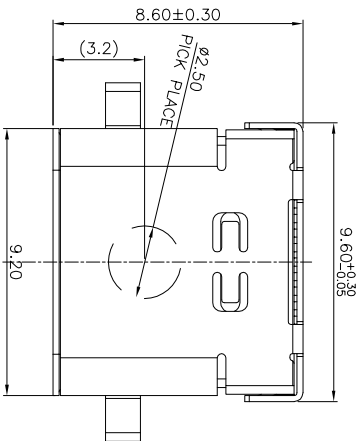

SECTION B-B

NOTES: 1. MATERIAL:

MOLDING: LCP UL94 V-0  
CONTACT: COPPER ALLOY.

GOLD PLATED Min ON CONTACT AREA, 100u"

Min TIN (LEAD FREE) ON SOLDER AREA,

SHELL: SUS304-H, T=0.30±0.03mm

50u" NICKEL PLATING OVER ALL.

SHLD: SUS304-H, T=0.12±0.03mm

2. MECHANICAL:

INSERTION: 5~20N.

EXTRACTION: 8~20N.

DURABILITY: 10000 CYCLES

3. ELECTRICAL:

CURRENT: 5A MIN FOR VBUS;

0.25A MIN FOR OTHER.

VOLTAGE: 20 V MAX

WITHSTANDING VOLTAGE: 100V AC.

CONTACT RESISTANCE: 40mΩ MAX.

INSULATION RESISTANCE: 100MΩ MIN.

4. ENVIRONMENTAL

TEMPERATURE RANGE -55°C ~ +85°C

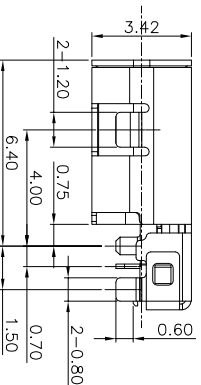
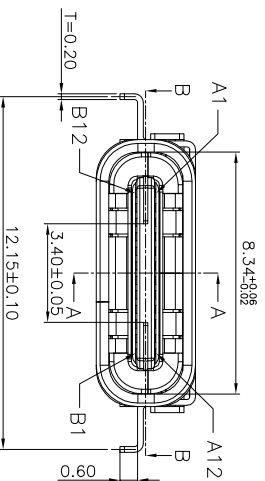

SECTION A-A

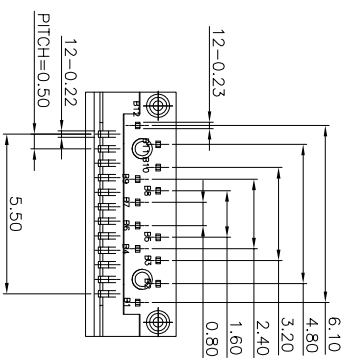

Detail A

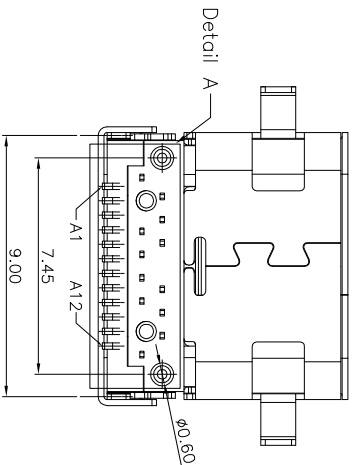

## 产品图

## 深圳市鑫风雷电子有限公司

PRODUCT CHART DWG

### 公差一览表

TOLERANCE UNLESS OTHERWISE	X'	X''	X'''	±5'	±2'	±1'	±0.5'
X	±0.30	X'	X''	±5'	±2'	±1'	±0.5'
X	±0.25	X'	X''	±2'	±1'	±0.5'	±0.5'
XXX	±0.15	XXX'	XXX''	±0.5'	±0.5'	±0.5'	±0.5'

单位 UNITS	MM	制图 DRAWING	王冠	产品料号 PRODUCT PART NO.	00501-UCAF011-X
比例 SCALE	1:1	审核 CHKD	雷永健	产品名称 PRODUCT NO.	TYPE C母座双壳带插后触DP-SMT 24P L=8.65
日期 DATE	2009/10/20	核准 APPD	雷永健	角法 VIEW	版本 VER
					A0

# ROHS 客户图

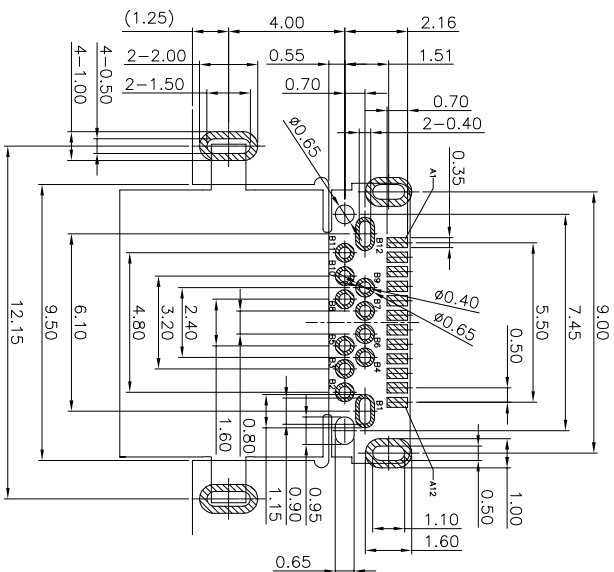
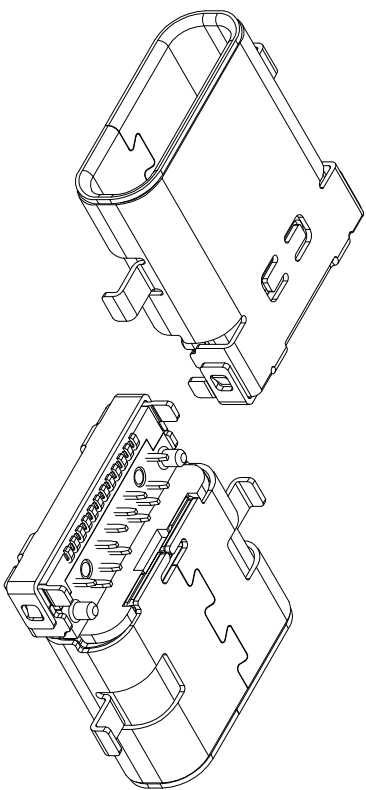

RECOMMEND P.C.B LAYOUT(COMPONENT SIDE)  
TOLERANCE FOR PCB LAYOUT IS ± 0.05  
KEEP OUT AREAS

目錄 MAPX	變更內容 MODIFICATION	日期 DATE
A0	NEW	09-10-20

USB TYPE-C FULL-FEATURED RECEPTACLE INTERFACE PIN ASSIGNMENTS

PIN	Signal Name	Description	PIN	Signal Name	Description
A1	GND	Ground return	B12	GND	Ground return
A2	SSTXp1	Positive half of first SuperSpeed TX differential pair	B11	SSRXp1	Positive half of first SuperSpeed RX differential pair
A3	SSTRx1	Negative half of first SuperSpeed TX differential pair	B10	SSRXn1	Negative half of first SuperSpeed RX differential pair
A4	Vbus	Bus Power	B9	Vbus	Bus Power
A5	CC1	Configuration Channel	B8	SBU2	Sideband Use (SBU)
A6	Dp1	Positive half of the USB 2.0 differential pair-Position 1	B7	Dn2	Negative half of the USB 2.0 differential pair-Position 2
A7	Dn1	Negative half of the USB 2.0 differential pair-Position 1	B6	Dp2	Positive half of the USB 2.0 differential pair-Position 2
A8	SR01	Sideband Use (SR0)	B5	CC2	Configuration Channel
A9	Vbus	Bus Power	B4	Vbus	Bus Power
A10	SSRXn2	Negative half of second SuperSpeed RX differential pair	B3	SSTXn2	Negative half of second SuperSpeed TX differential pair
A11	SSRXp2	Positive half of second SuperSpeed RX differential pair	B2	SSTXp2	Positive half of second SuperSpeed TX differential pair
A12	GND	Ground return	B1	GND	Ground return

## 产品图

### 公差一览表

公差一览表		单位	MM	制图	王冠	产品料号	00501-UCAF011-X
TOLERANCE UNLESS OTHERWISE		UNITS	MM	DRAWING	王冠	PRODUCT PART NO.	00501-UCAF011-X
X	±0.30	X'	±5°	审核	雷永健	产品名称	TYPE C母座双壳带插面USB-SMT 24P L-R-65
X	±0.25	X'	±2°	核准	雷永健	PRODUCT NO.	
XX	±0.30	XX'	±1°	日期	2009/10/20	角法	ISO
XXX	±0.15	XXX'	±0.5°	APPD		版本	V01R

## 深圳市鑫风雷电子有限公司

# ROHS 客户图

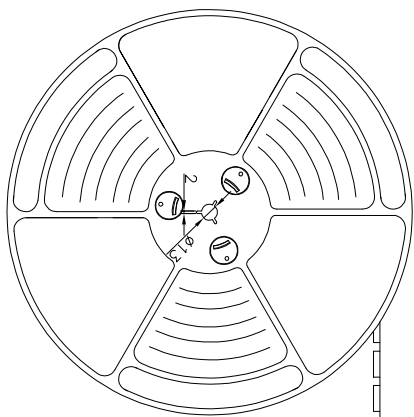

出料方向  
PULL OUT DIRECTION

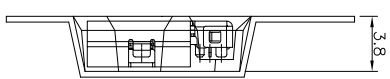
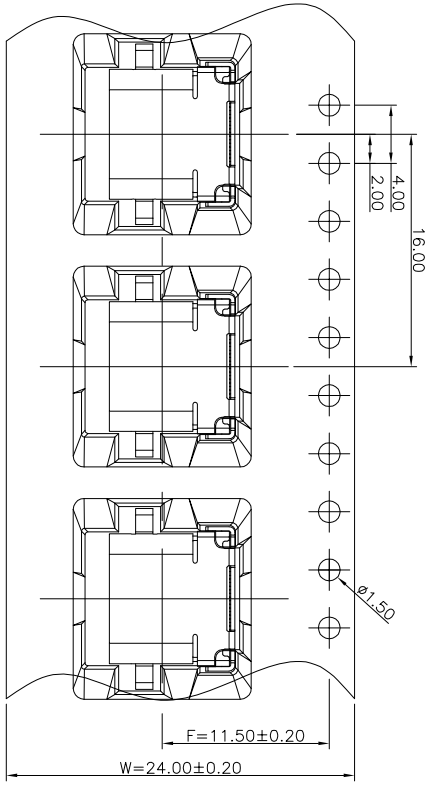
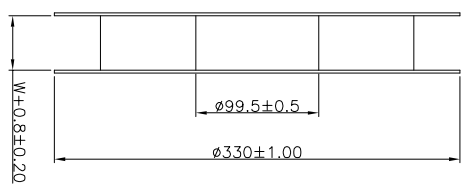

## NOTES

1. 帶子引導長度  
LEAD TAPE LENGTH  
出料方向  
PULL OUT DIRECTION

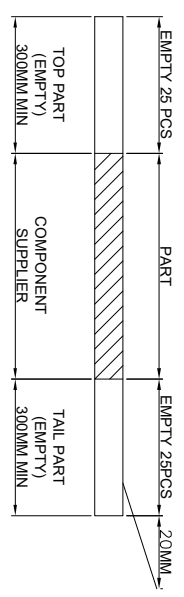

2. 上帶 剝力力為: 0.1~1.3N(10.2gf~130gf)  
PEELING OFF FORCE OF TOP TAPE: 0.1~1.3N(10.2gf~130gf)  
出貨運輸過程中一定注意:  
THIS REQUIREMENT SHOULD BE APPLIED AT SHIPMENT:  
卷帶在運輸過程中不能散開  
PEELING OFF SHOULD NOT BE ALLOWED DURING TRANSPORTATION

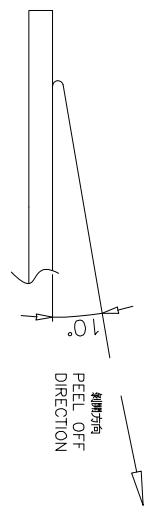

## 產品圖

## 深圳市鑫风雷电子有限公司

公差一览表  
TOLERANCE UNLESS OTHERWISE

X	±0.30	X'	±5°
X	±0.25	X'	±2°
XX	±0.30	XX'	±1°
.XXX	±0.15	.XXX'	±0.5°

單位 UNITS	MM	制圖 DRAWING	王冠	產品料號 PRODUCT PART NO.	00501-UCAF011-X
比例 SCALE	1:1	審核 CHECK	雷永健	產品名稱 PRODUCT NO.	TYPE C母板沉板雙光前插后插DIP-SMT 24P 1-8-65
日期 DATE	2009/10/20	核准 APPRO	雷永健	角法 VIEW	版本 VER
					A0

# RoHS 客户图

目錄 MAPX A0	變更內容 MODIFICATION NEW	日期 DATE 09-10-20
------------------	-----------------------------	------------------------

at small positioning hole of the carrier tape side).  
 ??? (?????????????)  
 Location of label sticking (label

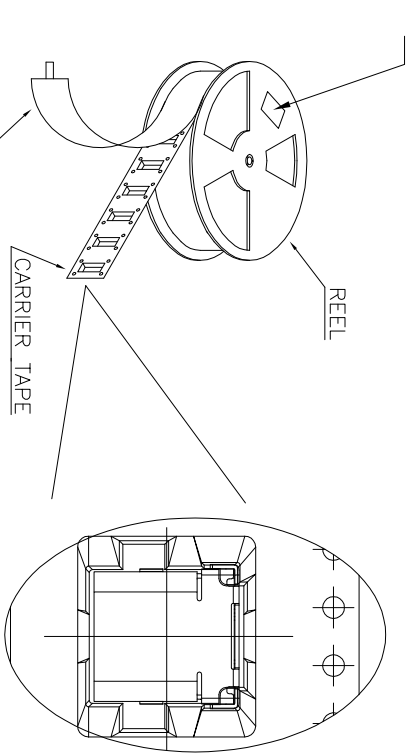
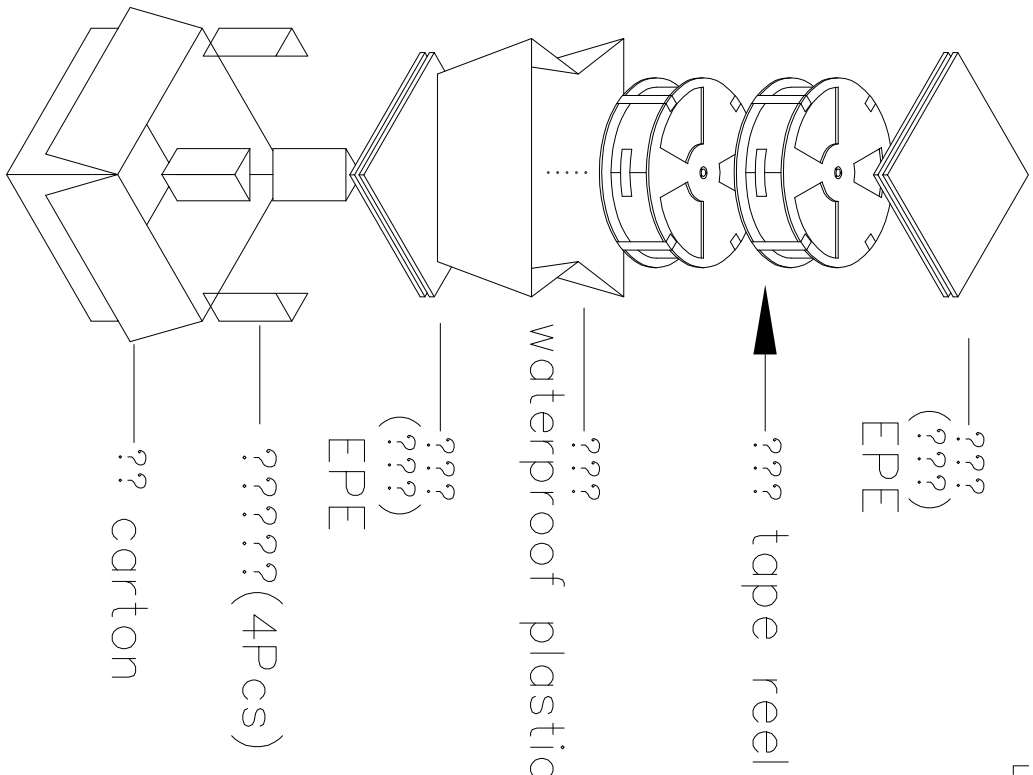

NOTE:

1. 每捲包裝數量及每箱裝箱數量如左下表格  
Packing qty of each reel & carton as below table shown.
2. 以上膠帶覆蓋下包裝帶經包裝機熱熔包裝  
Use cover tape to cover and hot melt machine to seal up.
3. 每個紙箱放2個珍珠棉  
Every carton use 2pcs EPE.
4. 將裝滿產品的卷盤放入紙箱並以膠帶封口  
Put reels in the carton and use adhesive tape to seal up.

## 產品圖

## 深圳市鑫風雷電子有限公司

PRODUCT CHAIR DWG

### 公差一览表

TOLERANCE UNLESS OTHERWISE	X'	X"	X'''	±5°	±2°	±1°	±0.5°
X	±0.30	X'	X''	±5°	±2°	±1°	±0.5°
X	±0.25	X'	X''	±2°	±1°	±0.5°	±0.5°
XX	±0.30	XX'	XX''	±1°	±0.5°	±0.5°	±0.5°
.XXX	±0.15	.XXX'	.XXX''	±0.5°	±0.5°	±0.5°	±0.5°

單位 UNITS	MM	制圖 DRAWING	王冠	產品料號 PRODUCT PART NO.	00501-UCAF011-X
比例 SCALE	1:1	審核 CHKD	雷永健	產品名稱 PRODUCT NO.	TYPE C每捲裝載24卷的插頁載011-SMT 24P 1-8x.65
日期 DATE	2009/10/20	核准 APPD	雷永健	角法 VIEW	
				版本 VER	A0

產品料號 (PRODUCT No.)	包裝容 PCS/REEL	量 REELS/CARTON	(PACKING CAPACITY)	量 N.W./PCS	量 N.W./BOX	量 G.W./BOX
X 001-UCAF011-X	1000	8	8000			