

RoHS 客户图

目錄 MAPX	變更內容 MODIFICATION	日期 DATE
A0	NEW	09-10-20

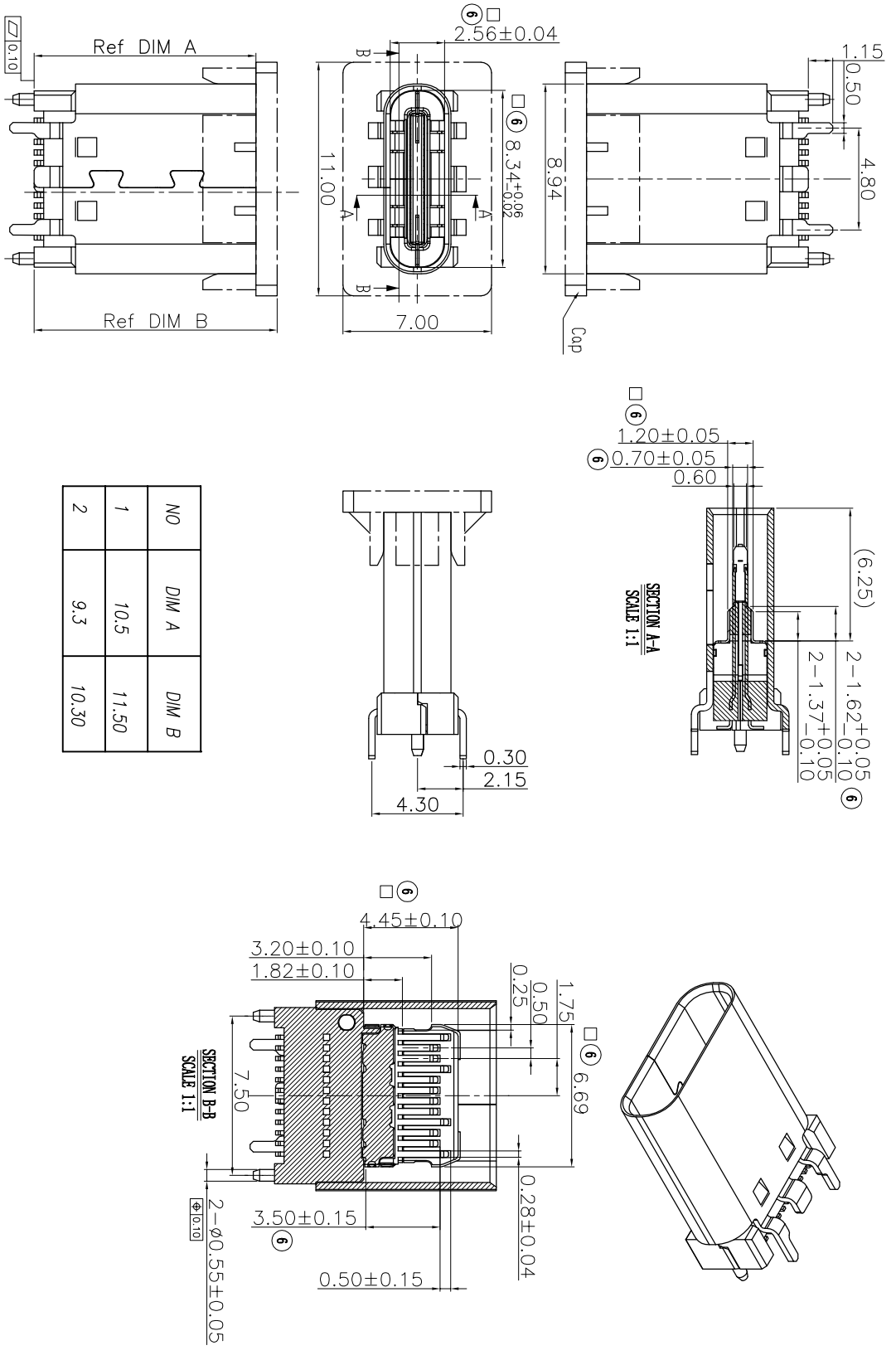

NO	DIM A	DIM B
1	10.5	11.50
2	9.3	10.30

产品图 PRODUCT CHART DWG			单位 UNITS			制图 DRAWING			产品料号 PRODUCT PART NO.			
公差一览表 TOLERANCE UNLESS OTHERWISE			MM			王冠			13001-UCAF002-X			
X	±0.30	X'	±5'	比例 SCALE			审核 CHKD			产品名称 TYPE		
.X	±0.25	.X'	±2'	1:1			雷永健			C母座24立式SMT H=10.5脚长1.15		
.XX	±0.30	.XX'	±1'	日期 DATE			核准 APPD			角法 VIEW		
.XXX	±0.15	.XXX'	±0.5'	2009/10/20			雷永健			版本 VER		
								A0				

深圳市鑫风雷电子有限公司

RoHS 客户图

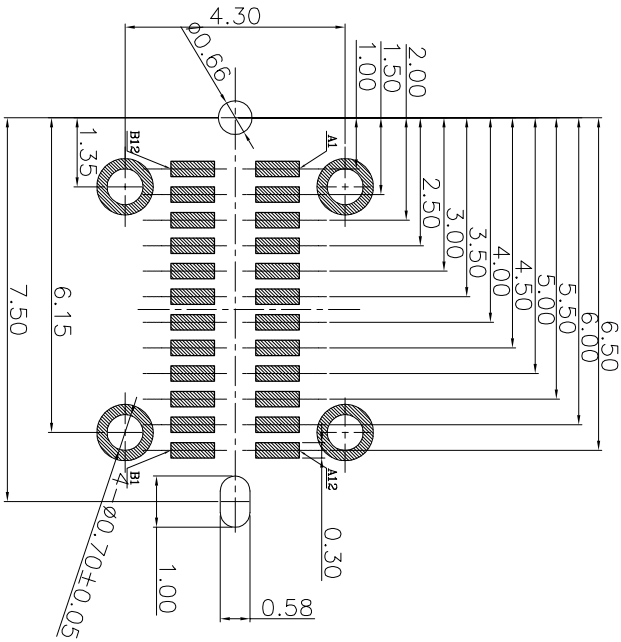
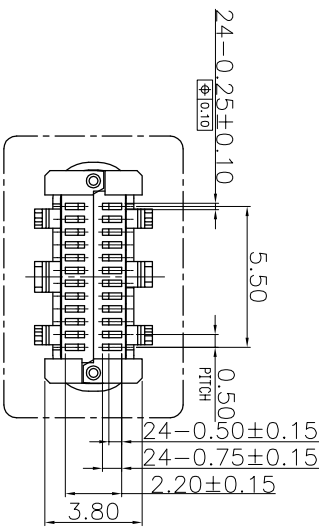

RECOMMENDED P.C.B. LAYOUT (T:1.00mm)
TOLERANCE UNSPECIFIED ±0.05mm

目錄 MAPX A0	變更內容 MODIFICATION NEW	日期 DATE 09-10-20
------------------	-----------------------------	------------------------

- SPECIFICATIONS:
- MECHANICAL :
 - INSERTION FORCE :5N~20N
 - WITHDRAWAL FORCE :8N~20N AFTER 10,000 CYCLES MATING: 2N MIN.
 - ELECTRICAL :
 - CONTACT CURRENT RATING: 3A .
 - VOLTAGE RATING :30V AC (rms)
 - WITHSTANDING VOLTAGE: 100 VAC FOR 1 MINUTE. INSULATION RESISTANCE: 100 MEGOHMS MIN.
 - CONTACT RESISTANCE: 40 MILLIOHMS MAX.
 - ENVIRONMENTAL :
 - OPERATING TEMPERATURE: -25°C TO +85°C

Pin	Signal Name	Description	Pin	Signal Name	Description
A1	GND	Ground return	B12	GND	Ground return
A2	SSTXp1	Positive half of first SuperSpeed TX differential pair	B11	SSRXp1	Positive half of first SuperSpeed RX differential pair
A3	SSTXn1	Negative half of first SuperSpeed TX differential pair	B10	SSRXn1	Negative half of first SuperSpeed RX differential pair
A4	Vbus	Bus Power	B9	Vbus	Bus Power
A5	CC1	Configuration Channel	B8	SRU2	Sideband Use (SRU)
A6	Dp1	Positive half of the USB 2.0 differential pair-Position 1	B7	Dm2	Negative half of the USB 2.0 differential pair-Position 2
A7	Dn1	Negative half of the USB 2.0 differential pair-Position 1	B6	Dp2	Positive half of the USB 2.0 differential pair-Position 2
A8	SRU1	Sideband Use (SRU)	B5	CC2	Configuration Channel
A9	Vbus	Bus Power	B4	Vbus	Bus Power
A10	SSRXn2	Negative half of second SuperSpeed RX differential pair	B3	SSTXn2	Negative half of second SuperSpeed TX differential pair
A11	SSRXp2	Positive half of second SuperSpeed RX differential pair	B2	SSTXp2	Positive half of second SuperSpeed TX differential pair
A12	GND	Ground return	B1	GND	Ground return

深圳市鑫风雷电子有限公司

产品图 PRODUCT CHART DWG		单位 UNITS		MM		制图 DRAWING		王冠		产品料号 PRODUCT PART NO.		13001-UCAF002-X	
公差一览表 TOLERANCE UNLESS OTHERWISE		比例 SCALE		1:1		审核 CHKD		雷永健		产品名称 PRODUCT NO.		TYPE C母座24P立式SMT H=10.5脚长1.15	
.XX ±0.30		.XX ±0.30		.XX ±1'		日期 DATE		2009/10/20		核法 VIEW		版本 VER	
.XXX ±0.15		.XXX ±0.5'				批准 APPD		雷永健				A0	

RoHS 客户图

目錄 MAPX	变更内容 MODIFICATION	日期 DATE
A0	NEW	09-10-20

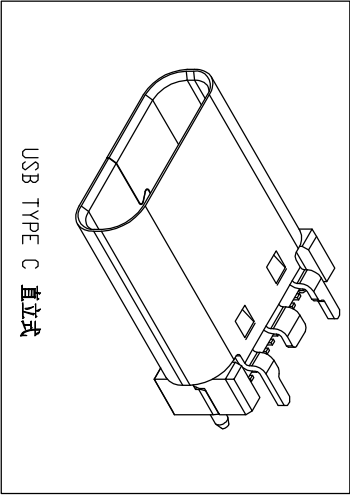
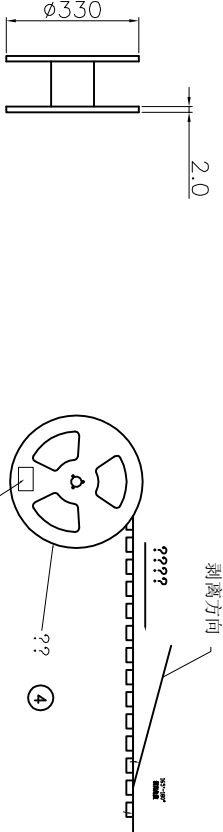
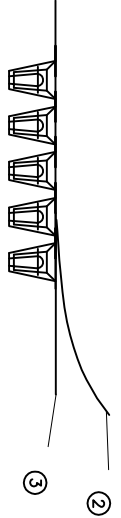
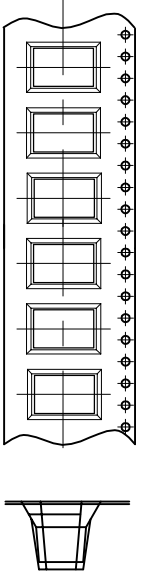
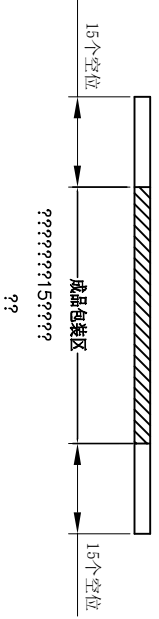

TABLE A

??	??	??	??
①	USB TYPE C ???		4.5 K
②	???	GP PET, W=21.0mm, 热融性	7.68*10
③	??	GP PBT W=24mm P=16mm T=0.50mm(t/7.68) 7.68*10	
④	??	??3.30*2.4, 0???	10PCS
⑤	??	390*390*3mm	2PCS
⑥	???	320(90+140+90)*300mm	4PCS
⑦	??	400*400*335mm K=K	1PCS
⑧	???	600*600*0.15	1PCS

产品图 PRODUCT CHART DWG

深圳市鑫风雷电子有限公司

公差一览表 TOLERANCE UNLESS OTHERWISE		单位 UNITS	制图 DRAWING	王冠	产品料号 PRODUCT PART NO.	13001-UCAF002-X
X	±0.30	X'	±5'	审核 CHKD	雷永健	产品名称 TYPE C母座24立式SMT H=10.5脚长1.15
X	±0.25	X'	±2'	核准 APPD	雷永健	角法 VIEW
.XX	±0.30	.XX'	±1'	日期 DATE	2009/10/20	版本 VER
.XXX	±0.15	.XXX'	±0.5'			A0

ROHS 客户图

目錄 MAPX A0	設定內容 MODIFICATION NEW	日期 DATE 09-10-20
------------------	-----------------------------	------------------------

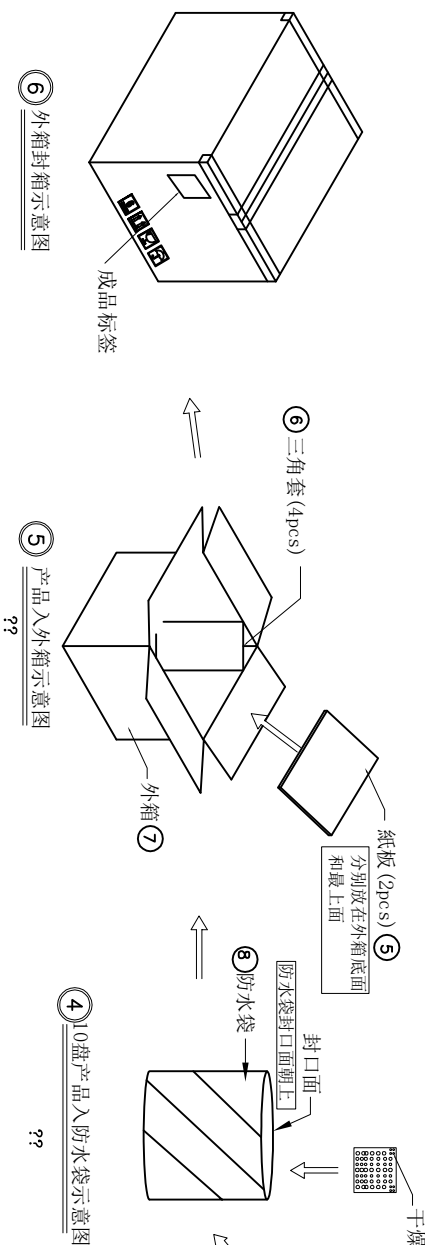
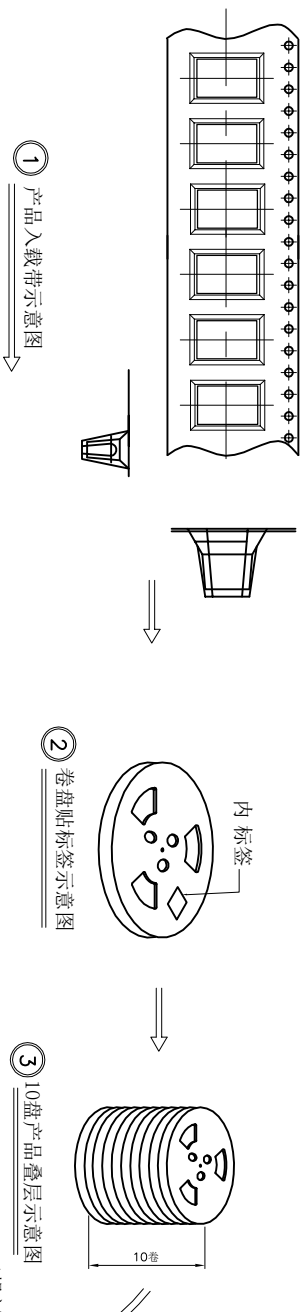

- 包装说明:
1. 将检验好的成品: SMT朝下放入载带底部;每卷装450PCS产品;具体如图一所示
 2. 将包装好的产品;每盘必需贴上内标签;具体如图二所示
 3. 将贴好内标签的产品每10盘叠一层装入防水袋中并加一包干燥剂;装好后将防水袋封好;具体如图三图四所示
 4. 先将1pcs平卡放入纸箱底部;然后将装好产品的防水袋装入纸箱中;防水袋热熔封口, 封口面需朝上;并将4PCS三角套分别装入4个角;如图五所示
 5. 装好后将1pcs平卡放入纸箱最上面并封好纸箱及贴好相关标签;具体如图六所示; (产品包装的标签, 如客户有要求, 请按客户要求包装出货)
 6. 载带前部和后面各留16PCS空格
 7. COVER与GARRY剥离力: 50-125g, 速度: 300mm/分钟左右, 剥离角度: 165°-180°

产品图

深圳市鑫风雷电子有限公司

公差一览表 TOLERANCE UNLESS OTHERWISE		单位 UNITS		制图 DRAWING		产品料号 PRODUCT PART NO.	
X	±0.30	X'	±5'	王冠	13001-UCAF002-X		
.XX	±0.25	.X'	±2'	雷永健			
.XX	±0.30	.XX'	±1'	雷永健			
.XXX	±0.15	.XXX'	±0.5'				
比例 SCALE		日期 DATE		审核 APPR		版本 VER	
1:1		2009/10/20		雷永健		A0	
产品名称 PRODUCT NO.		角法 VIEW					
TYPE C母座2P立式SMT H=10.5脚长L.15							