

ROHS 客户图

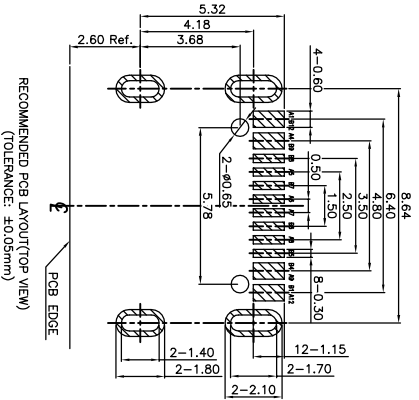
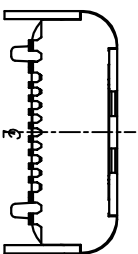
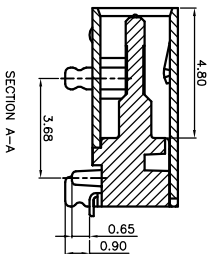
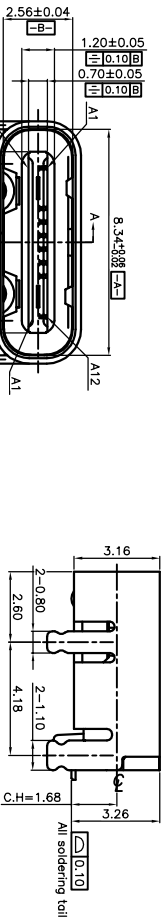
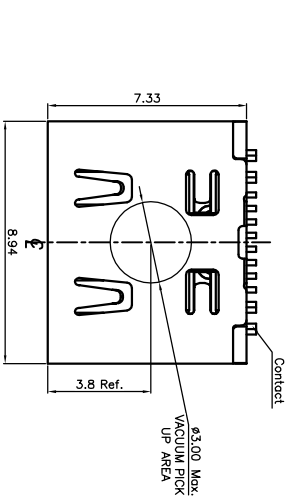
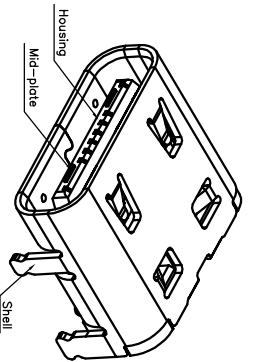

PIN ASSIGNMENT:

PIN NO.	Signal Name	PIN NO.	Signal Name
A1	GND	B12	GND
A4	VBUS	B9	VBUS
A5	CC1	B8	SBU2
A6	DP1	B7	DN2
A7	DN1	B6	DP1
A8	SBU1	B5	CC2
A9	VBUS	B4	VBUS
A12	GND	B1	GND

- Materials
 - Housing: LCP, Black, UL94 V-0;
 - Contact: High conductivity copper alloy, Gold Plating at mating area & solder tail, all over Nickel;
 - Shell: Stainless steel, oil over Nickel;
 - Mid-Plate: stainless steel;
- Ratings
 - Voltage Rating: 5V AC;
 - Current Rating: 5A ;
 - Operating Temperature: -40℉ ~ 85℉;
- Electrical Requirement:
 - ILCR: 40mΩ Max.(Initial), 50mΩ Max.(Final);
 - Dielectric Withstanding Voltage: 100V AC (RMS) for 1 minute;
 - Insulation Resistance: 100MΩ Min. @ 500V DC;
- Mechanical Performance:
 - Insertion force: 5~20N, (from 1~10,000 Cycles);
 - Withdrawal force: 8~20N,(from 1~1,000 Cycles); 6~20N,(from 1,001~10,000 Cycles);
 - Durability life: 10,000 Cycles;

Notes:

- Materials
 - Housing: LCP, Black, UL94 V-0;
 - Contact: High conductivity copper alloy, Gold Plating at mating area & solder tail, all over Nickel;
 - Shell: Stainless steel, oil over Nickel;
 - Mid-Plate: stainless steel;

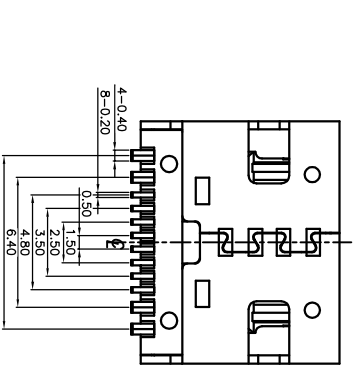

产品图

深圳市鑫风雷电子有限公司

公差一览表

TOLERANCE UNLESS OTHERWISE SPECIFIED	UNIT	MM	制图	王冠	产品料号	16003-UCAR001-X
X	±0.30	±0.30	审核	雷永健	产品名称	TYPE C母座板上单排16P
XX	±0.25	±0.25	核准	雷永健	图法	版本
XXX	±0.15	±0.15	日期	2009/10/20	视图	A0

1 2 3 4 5 6 7 8 9 10

RoHS

客户图

目錄 MAPX A0	變更內容 MODIFICATION NEW	日期 DATE 09-10-20
------------------	-----------------------------	------------------------

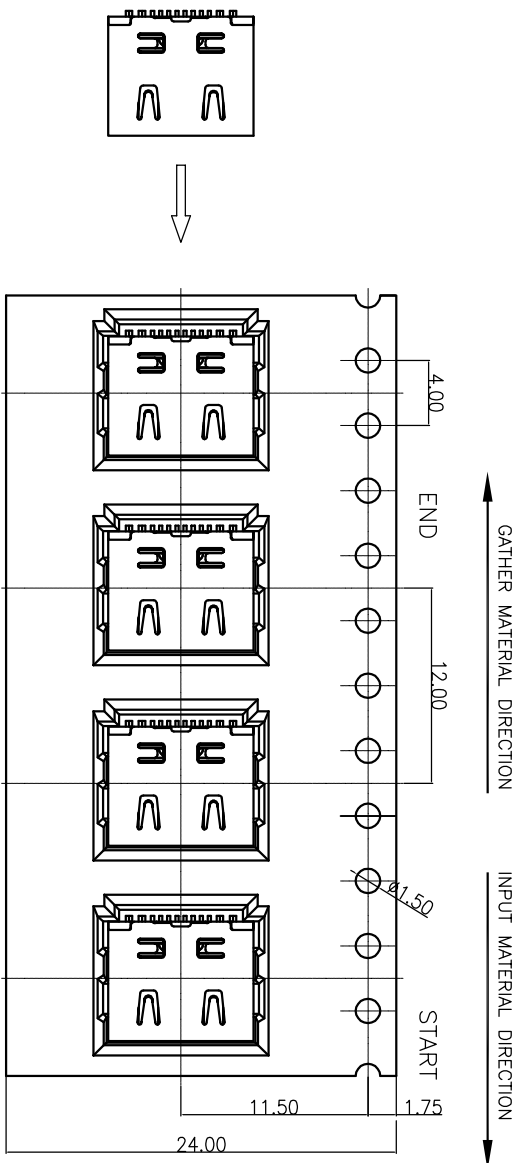
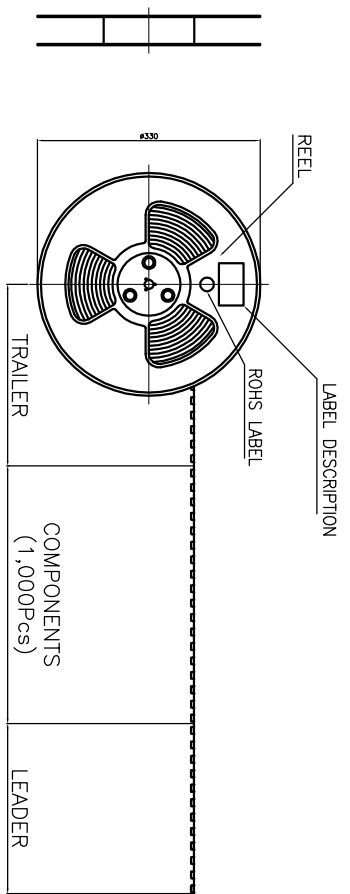

- NOTES:
1. THE START AND END OF EACH REEL,BASED ON THE ACTUAL QUANTITY, RESERVED 20--25PCS SPACE;
 2. PEEL OFF FORCE OF TOP TAPE: 10g~130g, PEEL DEG.:165度175?
 3. PEEL SPEED:250~300MM/MIN.
 4. CARTON SIZE: 350*350*315MM.
 4. QTY: 1,000PCS/REEL, 10REEL/CARTON, TOTAL 10,000PCS/CARTON.

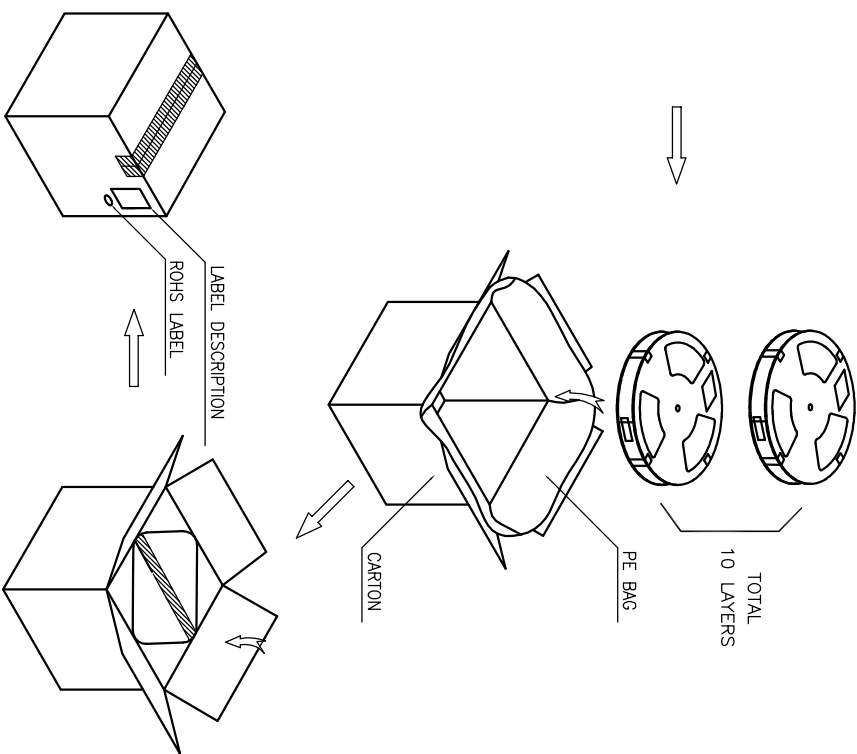

产品图

深圳市鑫风雷电子有限公司

公差一览表 TOLERANCE UNLESS OTHERWISE		单位 UNITS		制图 DRAWING		产品料号 PRODUCT PART NO.	
X	±0.30	X'	±5'	王冠	16003-1UCAR001-X		
X	±0.25	X'	±2'	雷永健			
.XX	±0.30	.XX'	±1'	雷永健			
.XXX	±0.15	.XXX'	±0.5'				

比例 SCALE	日期 DATE	审核 CHKD	核准 APPD	产品名称 PRODUCT NO.	角法 VIEW	版本 VER
1:1	2009/10/20	雷永健	雷永健	TYPE C母座板上单排16P		A0