

客户图

USB 2.0 C TYPE MALE

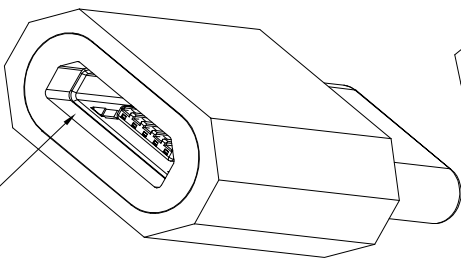

MICRO USB 2.0 BF

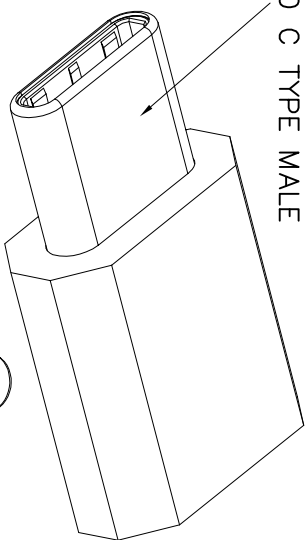
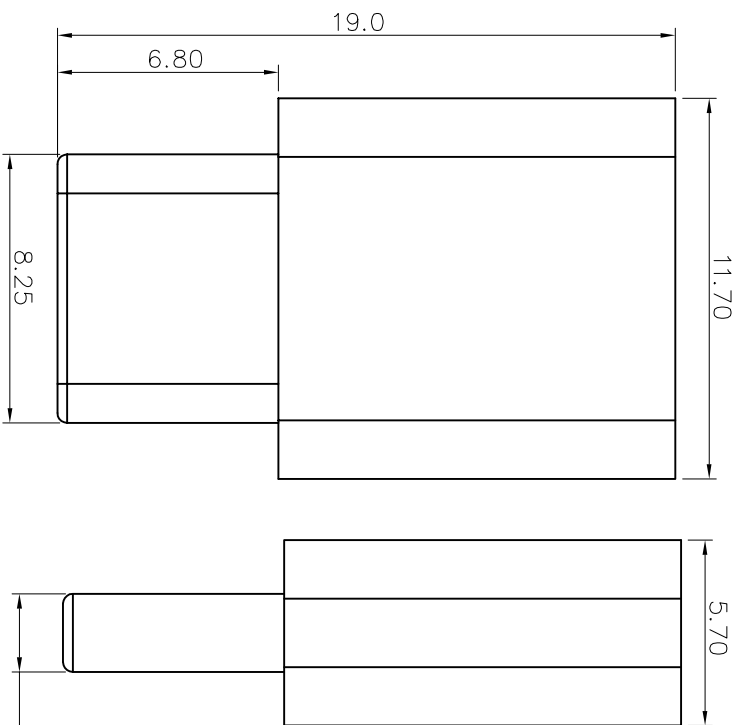
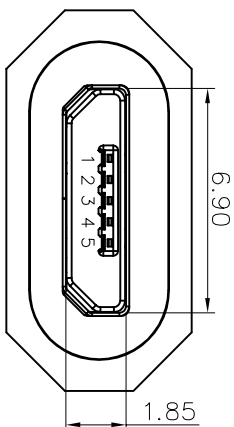
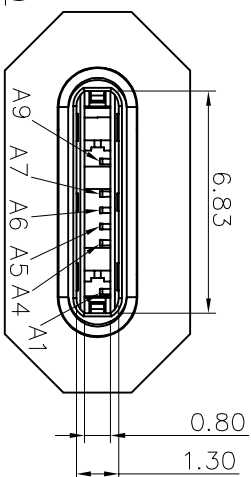

MICRO USB BF	PIN 1	PIN 2	PIN 3	PIN 4	PIN 5
SIGNAL NAME	VBUS	D-	D+	ID	GND
USB CM	A9	A7	A6	A5	A4
SIGNAL NAME	VBUS	D-	D+	CC1	VBUS
					GND

目錄 MAPX	修改內容 MODIFICATION	日期 DATE
A0	NEW	09-10-20

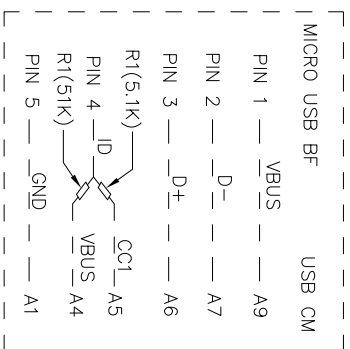

NOTE:

- MATERIAL:
 - INSULATOR: HIGH TEMPERATURE PLASTIC LCP; BLACK
 - CONTACT: COPPER ALLOY (T=0.15mm)
 - MICRO USB SHELL: SUS201 (T=0.30mm)
 - USB CM SHELL: SUS316L (T=0.15mm)
 - LATCH: SUS301 (T=0.40mm)
- ELECTRICAL CHARACTERISTICS:
 - CONTACT RESISTANCE: 80mΩ Max
 - CONTACT CURRENT RATING: 1.5 A
 - DIELECTRIC WITHSTANDING VOLTAGE: 100 V R.M.S.
 - INSULATION RESISTANCE 100 MEGOHMS Min
 - OPERATING TEMPERATURE: -25 °C ~ 75 °C
- MECHANICAL CHARACTERISTICS:
 - MATING FORCE: USB CM 5*20N & MICRO USB 35N Max.
 - UNMATED FORCE: USB CM 8*20N & MICRO USB 10N Min.
- PLATING
 - TERMINAL CONTACT: (SEE TAB) GOLD PLATING ALL OVER 50u" MIN NICKEL
 - SHELL: 50u" MIN. NICKEL ALL OVER

产品图

公差一览表

公差一览表 TOLERANCE UNLESS OTHERWISE SPECIFIED	单位 UNITS	比例 SCALE	日期 DATE
.XX	±0.30	1:1	2009/10/20
.XXX	±0.15		

制图 DRAWING	审核 CHKD	批准 APPRD	产品料号 PRODUCT PART NO.	产品名称 PRODUCT NO.	角法 VIEW	版本 VER
王冠	雷永健	雷永健	17002-UCTOMF01-X	USB 2.0 CM TO MICRO USB 2.0 母转接头带方护套		A0

深圳市鑫风雷电子有限公司