

# RoHS 客户图

目錄 MAPX	變更內容 MODIFICATION	日期 DATE
A0	NEW	09-10-20

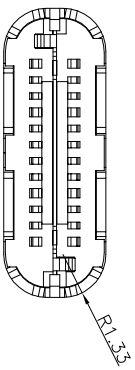
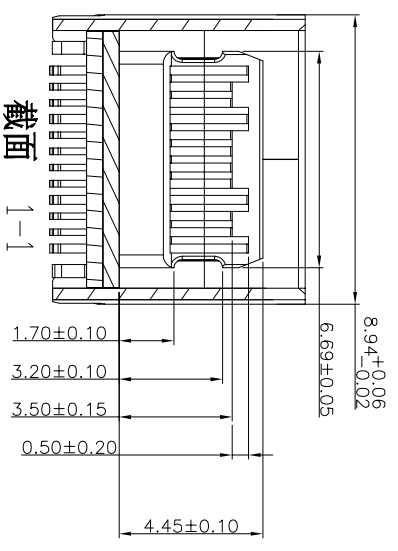
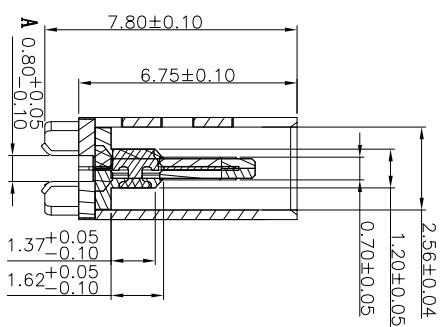
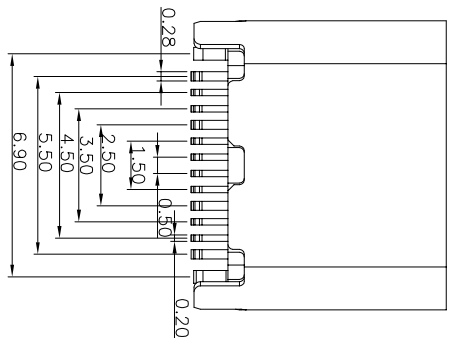
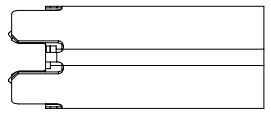
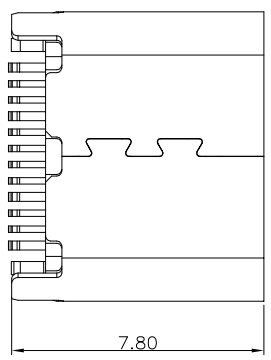
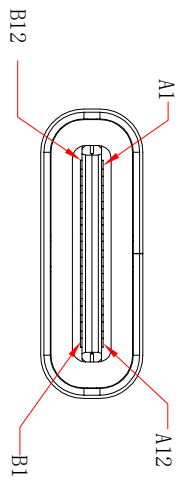
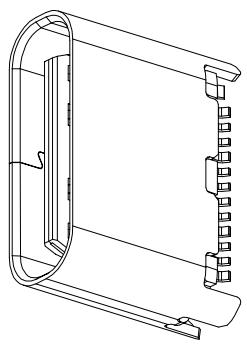

截面 A-A

NOTES:  
 1. MATERIAL: LCP UL94 V-0  
 MOLDING: COPPER ALLOY.  
 CONTACT: COPPER ALLOY.  
 GOLD PLATED 1u" Min ON CONTACT AREA.  
 GOLD PLATED Min ON SOLDER AREA.  
 SHELL: SUS304-H,T=0.30±0.03mm  
 50u" NICKEL PLATING OVER ALL.  
 SHIELD: SUS304-H,T=0.20±0.03mm  
 2. MECHANICAL:  
 INSERTION: 5~20N.  
 EXTRACTION: 8~20N AFTER TEST.  
 DURABILITY: 10000 CYCLES  
 SHELL SALT FOG FOR 48 H  
 3. ELECTRICAL:  
 CURRENT: 5A FOR VBUS;  
 1.25A FOR GND PIN.  
 0.25A FOR OTHER.  
 VOLTAGE: 20 V MAX  
 WITHSTANDING VOLTAGE: 100V AC R.M.S.  
 CONTACT RESISTANCE: 40mΩ MAX.  
 INSULATION RESISTANCE: 100MΩ MIN.  
 4. ENVIRONMENTAL  
 TEMPERATURE RANGE -25°C ~ +85°C

## 产品图

## 深圳市鑫风雷电子有限公司

公差一览表 TOLERANCE UNLESS OTHERWISE		单位 UNITS	MM	制图 DRAWING	王冠	产品料号 PRODUCT PART NO.	00302-UCAR008-X
X	±0.30	X'	±5'	审核 CHECK	雷永健	产品名称 PRODUCT NO.	TYPE C母座夹板24P 短体L=6.75
.XX	±0.30	.XX'	±2'	核准 APPD	雷永健	角法 VIEW	
.XXX	±0.15	.XXX'	±0.5'	日期 DATE	2009/10/20	版本 VER	A0