

RoHS 客户图

目錄 MAPX A0	變更內容 MODIFICATION NEW	日期 DATE 09-10-20
------------------	-----------------------------	------------------------

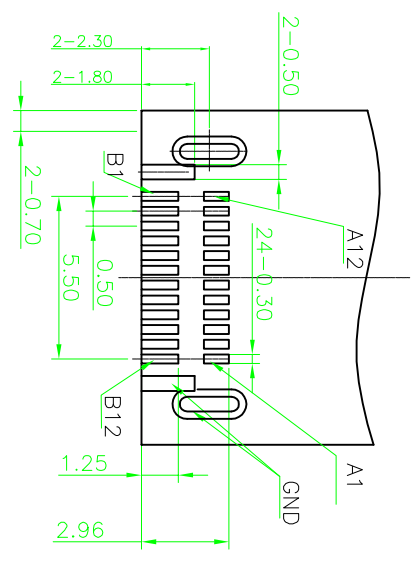

Recommended PCB Layout
Tolerance ±0.05

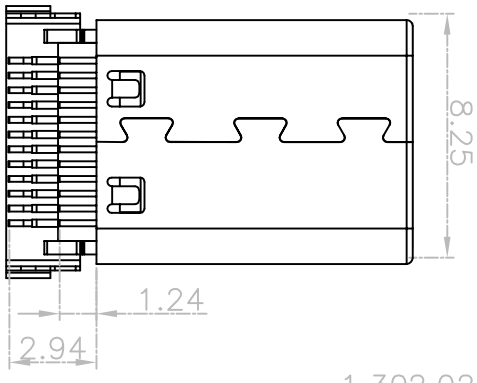
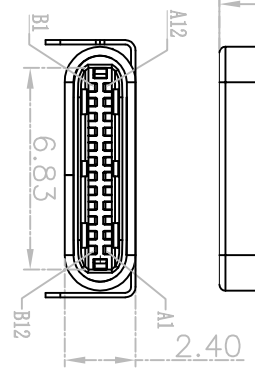
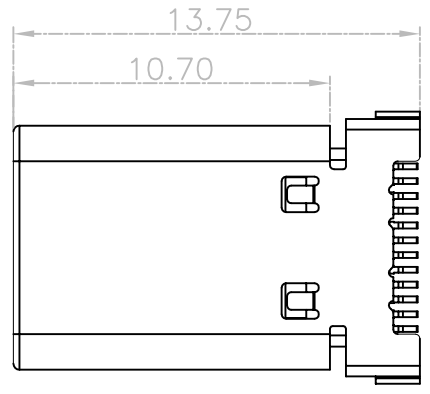
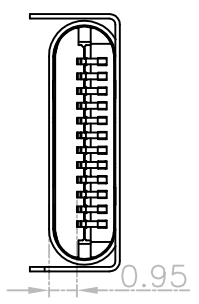
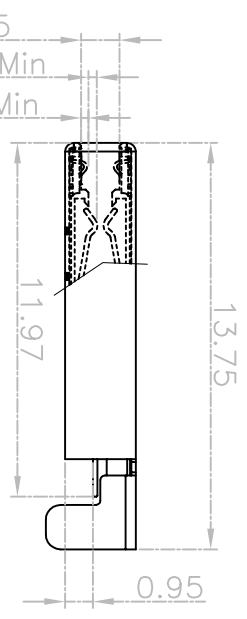

A12	A11	A10	A9	A8	A7	A6	A5	A4	A3	A2	A1
GND	RX2+RX2-	V _{bus}	SBU1	D-	D+	CC	V _{bus}	TX1-	TX1+	GND	GND
B1	B2	B3	B4	B5	B6	B7	B8	B9	B10	B11	B12

TID号: 7085

深圳市鑫风雷电子有限公司

产品图 PRODUCT CHART DWG		公差一览表 TOLERANCE UNLESS OTHERWISE		单位 UNITS		制图 DRAWING		产品料号 PRODUCT PART NO.		00304-UCAM004-X	
X	±0.30	X	±5°	X	MM	王冠	审核	雷永健	产品名称	TYPE	公头排针式双转SMT
X	±0.25	X	±2°	XX	1:1	日期	核准	雷永健	角法	版本	A0
XXX	±0.30	XXX	±1°	XXX	2009/10/20	DATE	APPD		VIEW	VER	