

RoHS 客户图

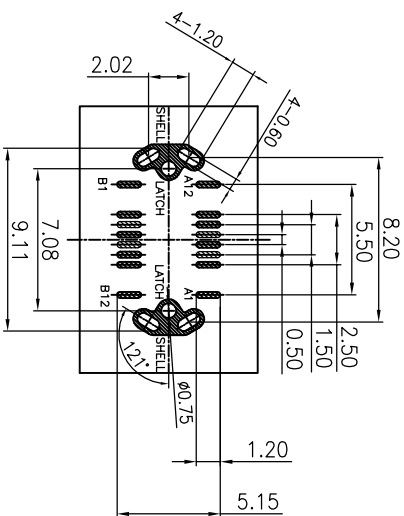

RECOMMEND P.C.B LAYOUT (COMPONENT TOP VIEW)
TOLERANCE: ±0.05

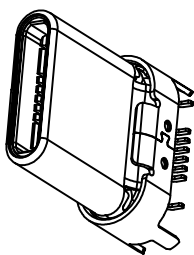
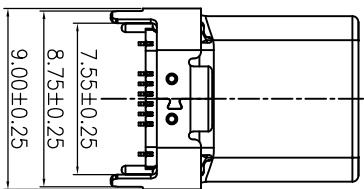
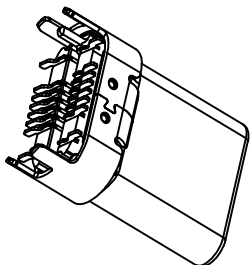
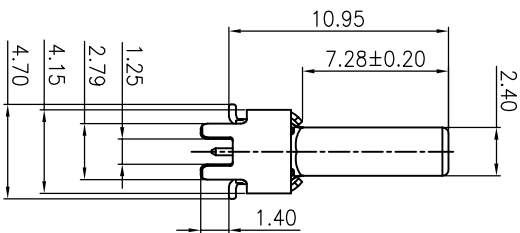
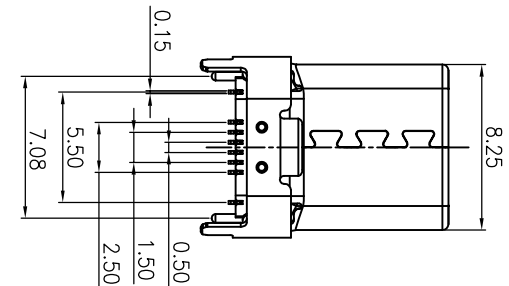
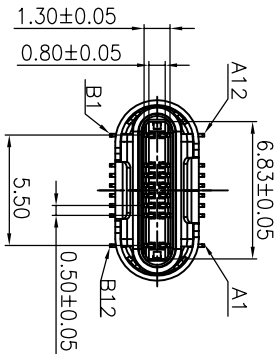
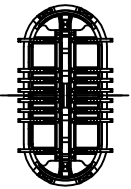

产品图

PRODUCT CHART DWG

公差一览表

| TOLERANCE UNLESS OTHERWISE | X | XX | XXX |
|----------------------------|-------|-------|-------|
| ±0.30 | ±0.25 | ±0.30 | ±0.15 |

深圳市鑫风雷电子有限公司
Shenzhen xinfenglei Electronic Co., Ltd

| 单位 UNITS | MM | 制图 DRAWTING | 王冠 | 产品料号 PRODUCT PART NO. | 00721-UCAM005-X |
|----------|------------|-------------|-----|-----------------------|---------------------------------|
| 比例 SCALE | 1:1 | 审核 CHECK | 雷永健 | 产品名称 PRODUCT NO. | TYPE C 16P 公头 V 式 SMT H=1.0, 95 |
| 日期 DATE | 2009/10/20 | 批准 APPD | 雷永健 | 角法 VIEW | 版本 VER |
| | | | | | A0 |

| 目錄 MAPX | 修改內容 MODIFICATION | 日期 DATE |
|---------|-------------------|----------|
| A0 | NEW | 09-10-20 |

ROHS 客户图

| | | |
|------------------|-----------------------------|------------------------|
| 目録 MAPX A0 | 变更内容 MODIFICATION NEW | 日期 DATE 09-10-20 |
|------------------|-----------------------------|------------------------|

NOTES:

- MATERIAL
 - HSG: HIGH TEMPERATURE THERMOPLASTIC UL94V-0; COLOR: BLACK
 - HOLDER: HIGH TEMPERATURE THERMOPLASTIC UL94V-0; COLOR: BLACK
 - CONTACT: COPPER ALLOY
 - LATCH: STAINLESS STEEL
 - SHELL: STEEL
 - OUT SHELL: STEEL
- FINISH:
 - CONTACT:
 - 5u" [0.127um] MIN. Au PLATING ON CONTACT AREA.
 - 100u" [2.54um] MIN. TIN PLATING ON SOLDER TAIL AREA.
 - 50u" [1.27um] MIN. NICKEL UNDERPLATING ON ALLOVER AREA.
 - LATCH:
 - 100u" [2.54um] MIN. TIN PLATING ON SOLDER TAIL AREA.
 - 50u" [1.27um] MIN. NICKEL UNDERPLATING ON ALLOVER AREA.
 - SHELL
 - PEARL NICKEL
 - OUT SHELL
 - WELDABLE NICKEL
- DIELECTRIC WITHSTANDING VOLTAGE: 300V AC/MINUTE FOR PER PIN.
- INSULATION RESISTANCE: 100MΩ BETWEEN ADJACENT CONTACTS AT 300V DC.
- TEMPERATURE RISING: 5A 30V FOR VBUS AND GND PIN.
- DATE CODE INFORMATION:

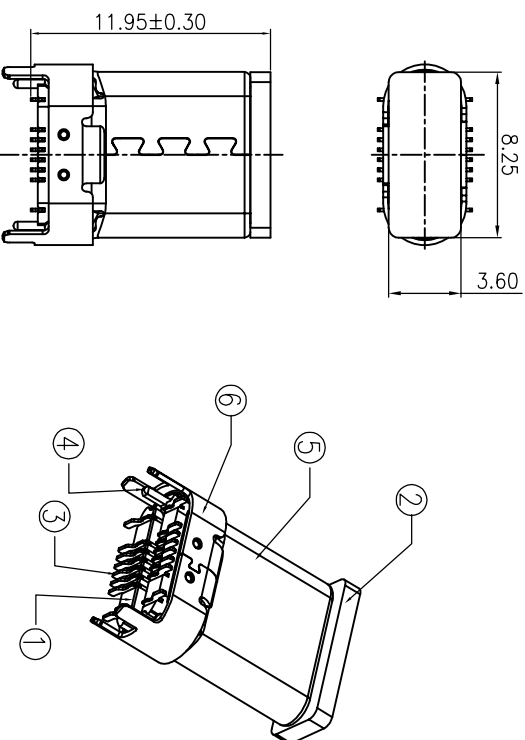

PLUG WITH HOLDER

PINS DESCRIPTION PLUG FRONT VIEW

| | | | | | | | | | | | |
|-----|-----|-----|------|-------|----|----|------|------|-----|-----|-----|
| A12 | A11 | A10 | A9 | A8 | A7 | A6 | A5 | A4 | A3 | A2 | A1 |
| GND | | | VBUS | SBU1 | D- | D+ | CC | VBUS | | GND | |
| GND | | | VBUS | VCONN | | | SBU2 | VBUS | | GND | |
| B1 | B2 | B3 | B4 | B5 | B6 | B7 | B8 | B9 | B10 | B11 | B12 |

产品图

PRODUCT CHART DWG

公差一览表

| TOLERANCE UNLESS OTHERWISE | 公差 |
|----------------------------|-------|
| X | ±0.30 |
| .XX | ±0.25 |
| .XXX | ±0.15 |

深圳市鑫风雷电子有限公司
Shenzhen xinfenglei Electronic Co., Ltd

| | |
|--------------------------|----------------------------|
| 单位 UNITS | MM |
| 比例 SCALE | 1:1 |
| 日期 DATE | 2009/10/20 |
| 制图 DRAWING | 王冠 |
| 审核 CHKD | 雷永健 |
| 核准 APPD | 雷永健 |
| 产品料号 PRODUCT PART NO. | 00721-UCAM005-X |
| 产品名称 PRODUCT NO. | TYPE C 16P公头V式SMT H=1.0.95 |
| 角法 VIEW | |
| 版本 VER | A0 |

RoHS 客户图

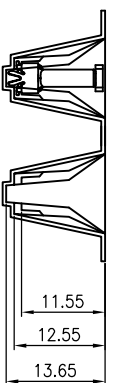
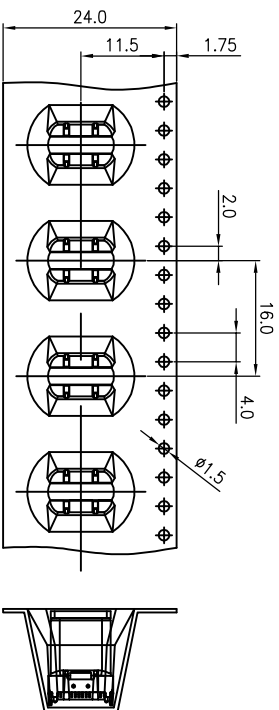
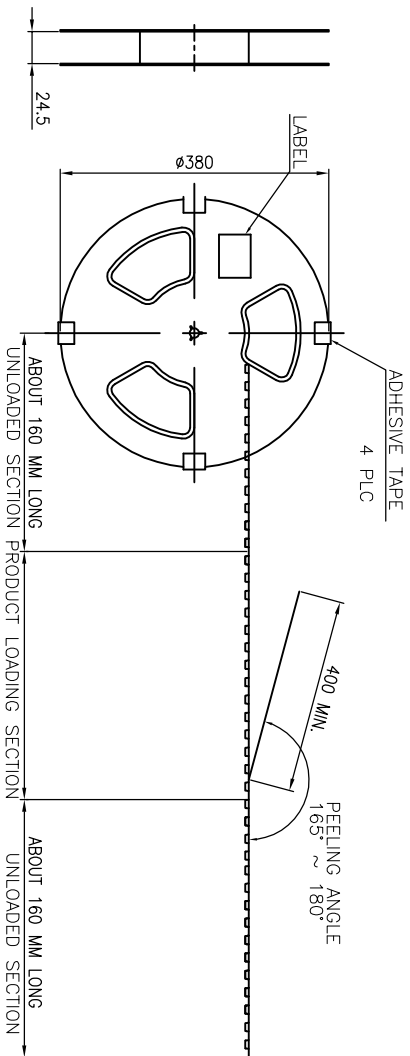

- NOTES:
1. MATERIAL:
COVER TAPE: PET, COLOR: TRANSPARENT;
CARRIER TAPE: PS, COLOR: TRANSPARENT
REEL: PS, COLOR: BLUE
 2. QUANTITY: SEE TABLE
 3. WEIGHT: SEE TABLE
 4. PEELING RESISTANCE: 10gf~130gf (for 12~56mm)
 5. PEELING SPEED: 300mm/MINUTES

| | | |
|----------|-----------|---------|
| 400 | 8 | 3200 |
| PCS/REEL | REELS/BOX | PCS/BOX |

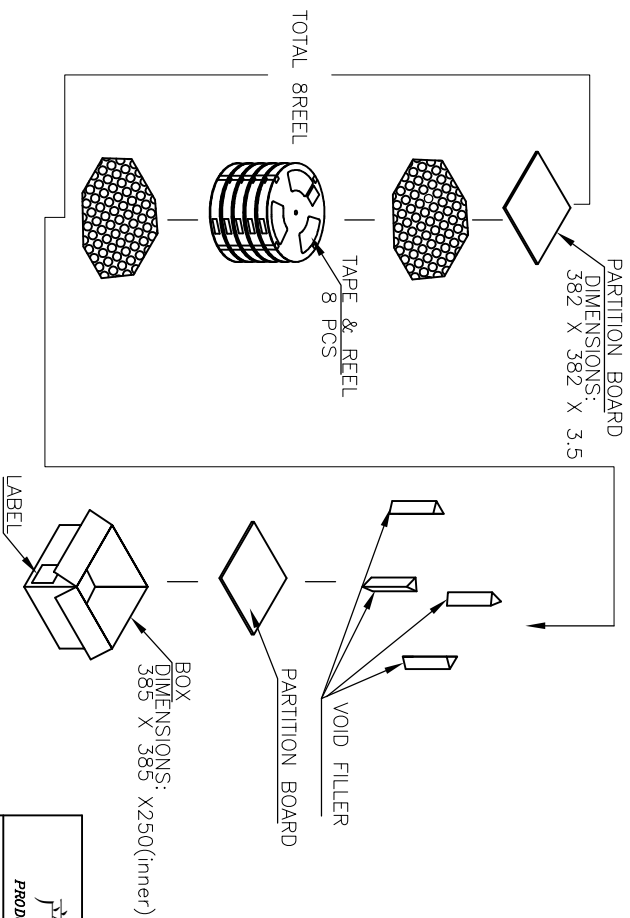

| 产品图 | | 公差一览表 | | 单位 | | 比例 | | 日期 | | 制图 | | 审核 | | 核准 | | 角法 | | 版本 | |
|-------------------|-------|----------------------------|-------|-------|-----|------------|-----|------|-----------------|--------------------------------|--|-------|--|-------|--|------|--|-----|--|
| PRODUCT CHART DWG | | TOLERANCE UNLESS OTHERWISE | | UNITS | | SCALE | | DATE | | DRAWING | | CHECK | | APPRO | | VIEW | | VER | |
| X | ±0.30 | X' | ±5' | MM | 1:1 | 2009/10/20 | 王冠 | 雷永健 | 00721-UCAM005-X | TYPE C 16P 公头 立式 SMT H=1.0, 95 | | | | | | | | | |
| .XX | ±0.25 | .X' | ±2' | | | | 雷永健 | 雷永健 | | | | | | | | | | | |
| .XXX | ±0.15 | .XXX' | ±0.5' | | | | 雷永健 | 雷永健 | | | | | | | | | | | |

深圳市鑫风雷电子有限公司
Shenzhen xinfenglei Electronic Co., Ltd