

ROHS

客户图

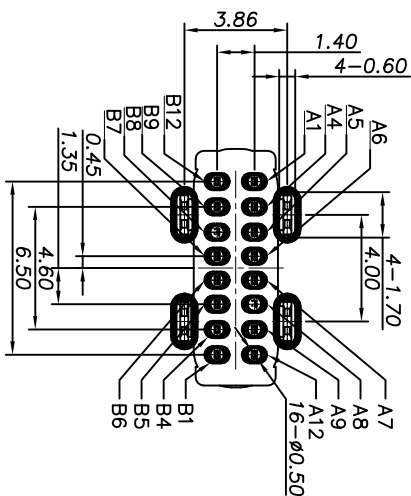

RECOMMENDED P.C.B. LAYOUT
TOLERANCE UNSPECIFIED ±0.05mm

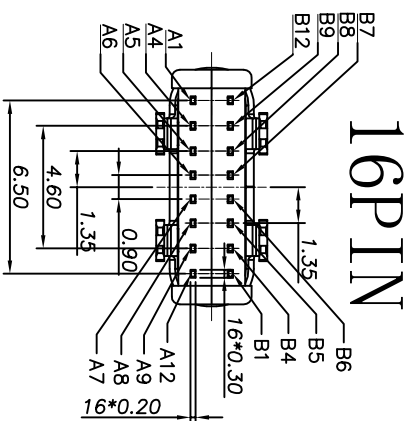
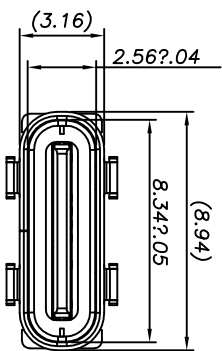
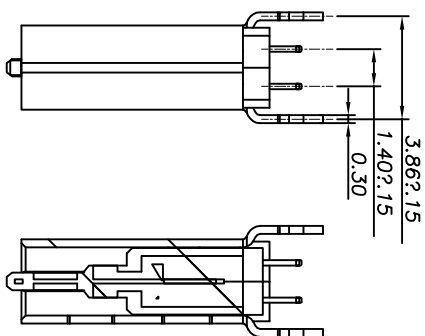
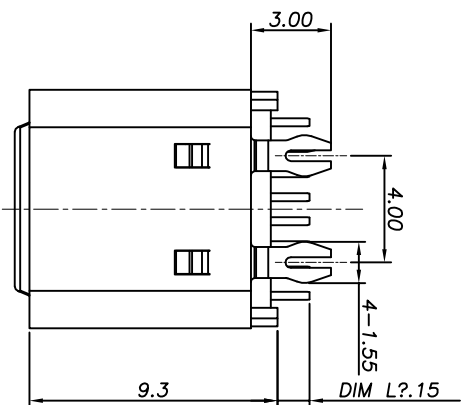

目錄 MAPX	變更內容 MODIFICATION	日期 DATE
A0	NEW	09-10-20

- NOTE:
- MATERIAL SPECIFICATION:
 - 1.1.HOUSING:HIGH TEMPERATURE RESISTANT PLASTIC,UL94 V-0.
 - 1.2.CONTACTS:COPPER ALLOY
 - 1.3.MID PLATE: STAINLESS STEEL
 - 1.4.FRONT SHELL: STAINLESS STEEL
 - MECHANICAL PERFORMANCE,
 - 2.1.INSERTION FORCE: 5~20N.
 - 2.2.REMOVAL FORCE: 8~20N.
 - 2.3.DURABILITY: 10000 CYCLES.
 - ELECTRICAL PERFORMANCE,
 - 3.1. CURRENT RATING:3/5 A VOLTAGE RATING:20V
 - 3.2. LCR: VBUS & GND PINS AND OTHER PINS: 40mΩ/PIN MAX. SHIELD: 50mΩ/MAX. LCR MAX. CHANGE OF ALL PINS: 10mΩ.
 - 3.3.INSULATION RESISTANCE: 100MΩ MIN.
 - 3.4.DIELECTRIC WITHSTAND VOLTAGE:AC 100V FOR 1 MINUTE.
 - ENVIRONMENTAL PERFORMANCE:
 4. OPERATING TEMPERATURE: -25°C~+85°C.
 5. IR REFLOW: THE PEAK TEMPERATURE ON THE BOARD SHALL BE MAINTAINED FOR 10 SECONDS AT 260°C.

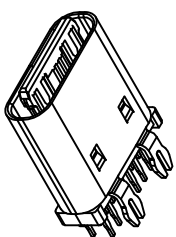
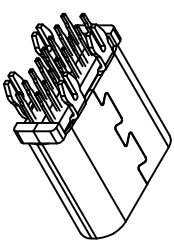

产品图

PRODUCT CHART DWG

公差一览表

TOLERANCE UNLESS OTHERWISE

公差	公差	公差	公差
X	±0.30	X	±5°
XX	±0.25	X'	±2°
XXX	±0.20	XX'	±1°
XXX	±0.15	XXX'	±0.5°

深圳市鑫风雷电子有限公司

Shenzhen xinfenglei Electronics Co., Ltd

单位 UNITS	MM	制图 DRAWING	王冠 Wangguan	产品料号 PRODUCT PART NO.	00724-UCAF005-X
比例 SCALE	1:1	审核 CHKD	雷永健 Lei Yongjian	产品名称 PRODUCT NO.	Type C 16p母座180度插板H=9.3
日期 DATE	2009/10/20	核准 Appd	雷永健 Lei Yongjian	联系方式 Machbox/ web	mailbox: sale1@xfll.com.com www: xfll.com.com