

1 2 3 4 5 6 7 8 9 10

**RoHS**

客户图

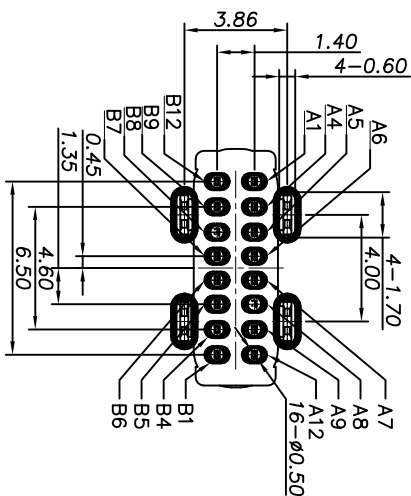
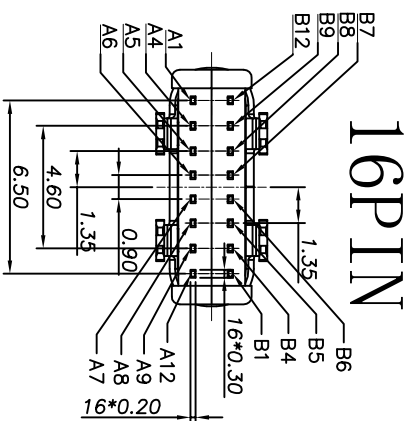

RECOMMENDED P.C.B. LAYOUT  
TOLERANCE UNSPECIFIED ±0.05mm

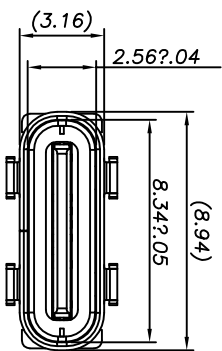
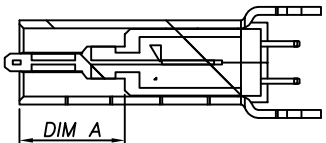
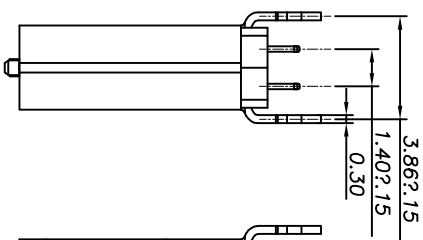
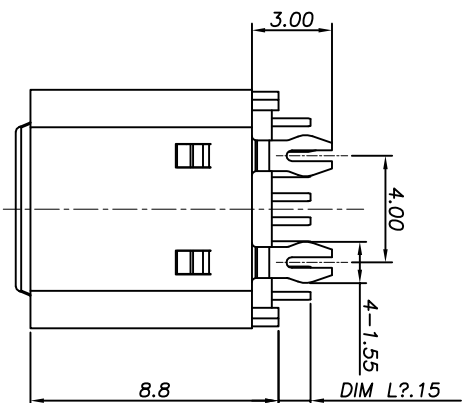

目錄 MAPX	變更內容 MODIFICATION	日期 DATE
A0	NEW	09-10-20

- NOTE:
1. MATERIAL SPECIFICATION:
- 1.1.HOUSING:HIGH TEMPERATURE RESISTANT PLASTIC,UL94 V-0.
  - 1.2.CONTACTS:COPPER ALLOY
  - 1.3.MID PLATE: STAINLESS STEEL
  - 1.4.FRONT SHELL: STAINLESS STEEL
2. MECHANICAL PERFORMANCE,
- 2.1.INSERTION FORCE: 5~20N.
  - 2.2.REMOVAL FORCE: 8~20N.
  - 2.3.DURABILITY: 10000 CYCLES.
3. ELECTRICAL PERFORMANCE,
- 3.1. CURRENT RATING:3/5 A
  - 3.2. LCR: VBUS & GND PINS AND OTHER PINS: 40mΩ/PIN MAX. SHIELD: 50mΩ/MAX. LCR MAX: CHANGE OF ALL PINS: 10mΩ.
  - 3.3.INSULATION RESISTANCE: 100MΩ MIN.
  - 3.4.DIELECTRIC WITHSTAND VOLTAGE:AC 100V FOR 1 MINUTE.
4. ENVIRONMENTAL PERFORMANCE:
- OPERATING TEMPERATURE: -25°C~+85°C.
5. IR REFLOW:  
THE PEAK TEMPERATURE ON THE BOARD SHALL BE MAINTAINED FOR 10 SECONDS AT 260°C.

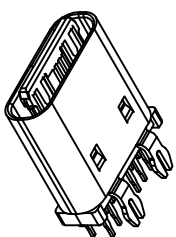
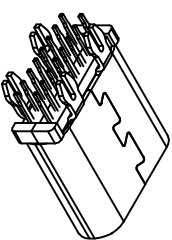

产品图

PRODUCT CHART DWG

公差一览表

TOLERANCE UNLESS OTHERWISE	公差一览表	单位 UNITS	比例 SCALE	日期 DATE	制图 DRAWING	审核 CHKD	核准 APPD	产品料号 PRODUCT PART NO	产品名称 PRODUCT NO	联系方式 MAILBOX
X	±0.30	X'	±5'		王冠 Wangguan	雷永健 Leiyongjian	雷永健 Leiyongjian	00724-UCAR004-X	Type C 16p母座180度插板H=8.8	mailto:sale1@xfll.com
XX	±0.25	X''	±2'		雷永健 Leiyongjian	雷永健 Leiyongjian	雷永健 Leiyongjian			www.xfll.com.com
XXX	±0.15	XXX'	±1.5'	2009/10/20	核 A1p1d	核 A1p1d	核 A1p1d			

深圳市鑫风雷电子有限公司  
Shenzhen xinfenglei Electronics Co., Ltd