

# ROHS 客户图

目錄  
MAPX  
A0

變更內容  
MODIFICATION  
NEW

日期  
DATE  
09-10-20

防水塑胶PC

材质：硅胶

- NOTES:
- 1.HOUSING: SEE NOTES. UL94V-0.
  - TERMINAL: SEE NOTES.
  - SHELL: SEE NOTES.
- SPECIFICATION:
- 1.ELECTRICAL CHARACTERISTIC:
    - CONTACT RESISTANCE: 30MΩ MAX
    - DIELECTRIC WITHSTANDING VOLTAGE: 500V AC FOR 1MIN
    - INSULATION RESISTANCE: 1000MΩ MIN
  - 2.MECHANICAL CHARACTERISTIC:
    - INSERTION FORCE: 35N(3.57KGF) MAX
    - EXTRACTION FORCE: 10~35N(1.02~3.57KGF)MIN
    - DURABILITY: 1500 CYCLES EXTRACTION FORCE: 10~35N 5000 CYCLES MIN
    - 5000 CYCLES EXTRACTION
- FORCE: 3~35N  
3.ENVIRONMENTAL:  
OPERATING TEMPERATURE: -55℃+85℃

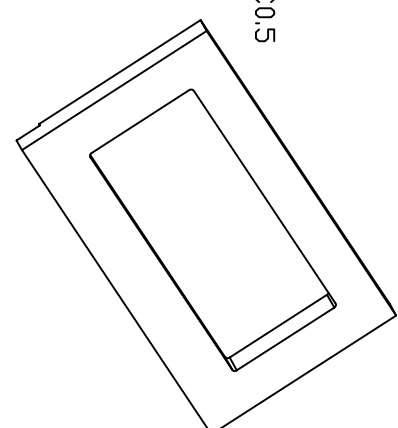
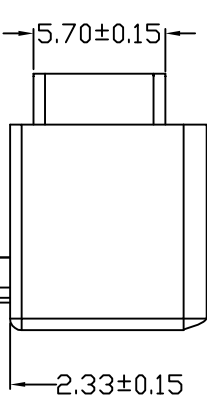
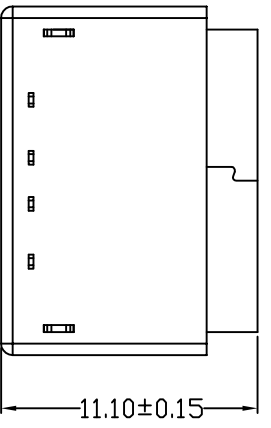
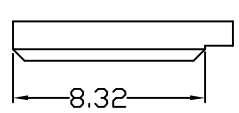
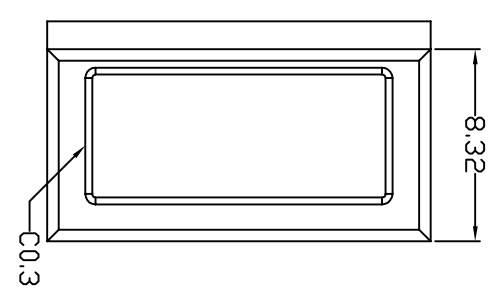
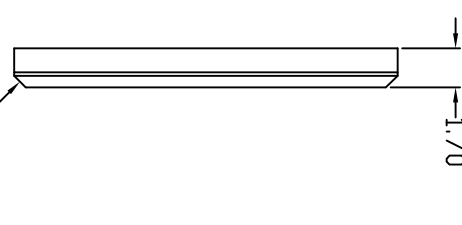
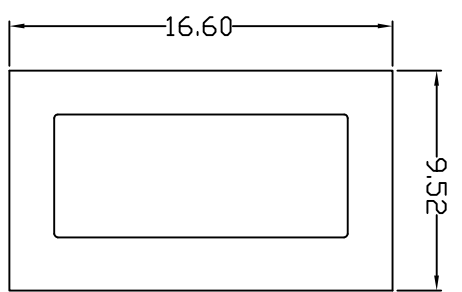
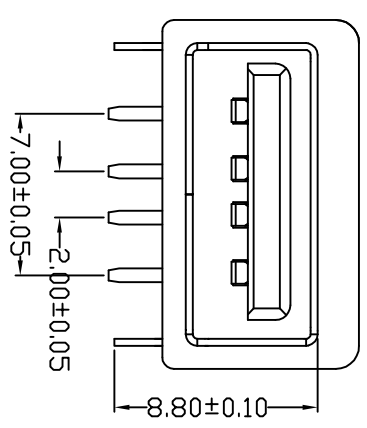
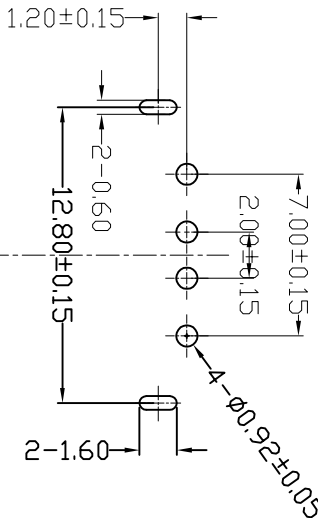
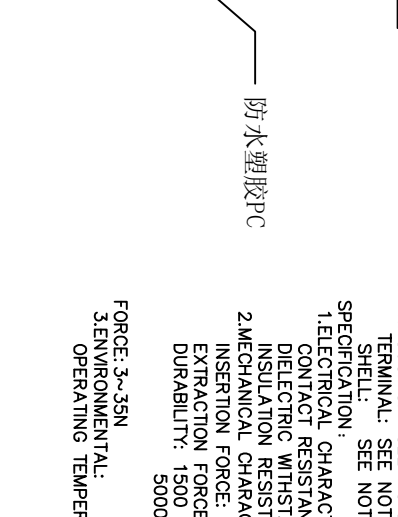
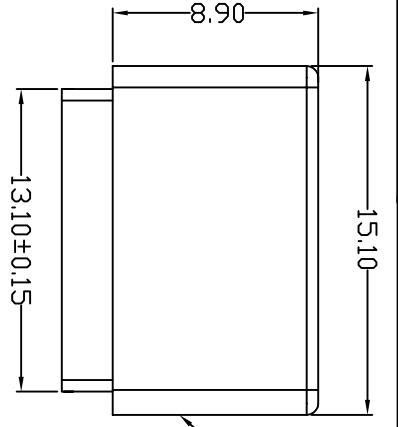

## 产品图

## 深圳市鑫风雷电子有限公司

公差一览表		单位	MM	制图	王冠	产品料号	01004-10DF003-R
TOLERANCE UNLESS OTHERWISE	UNITS	SCALE	DRAWING	审核	雷永健	产品名称	10.0 USB AF 90度后脚脚壳 H=6.2 防水型
X ±0.30	X'	±5'	1:1	核准 <td>雷永健 <th>角法</th> <td>100°</td> </td>	雷永健 <th>角法</th> <td>100°</td>	角法	100°
X ±0.25	X'	±2'	2009/10/20	版本 <td></td> <td>VER <td>A0</td> </td>		VER <td>A0</td>	A0
XX ±0.30	XX'	±1'	DATE				
XXX ±0.15	XXX'	±0.5'					

此图由Autodesk教育版产品制作 THAT IS PROPRIETARY TO XINFENGLI ELECTRONIC CO.,LTD AND SHOULD NOT BE USED WITHOUT WRITTEN PERMISSION