

# RoHS 客户图

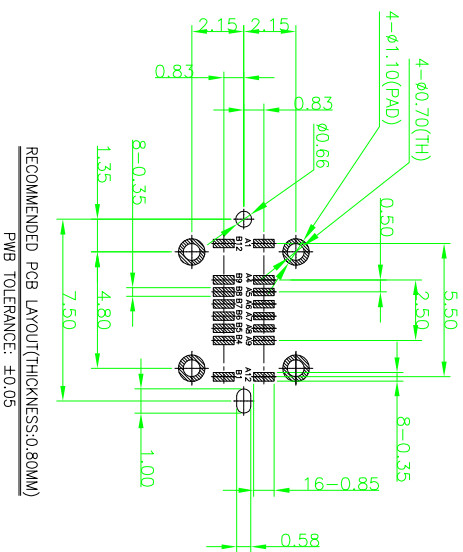
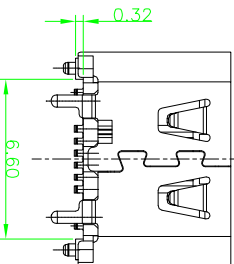
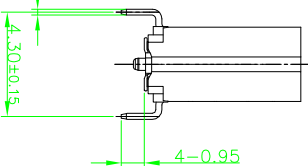
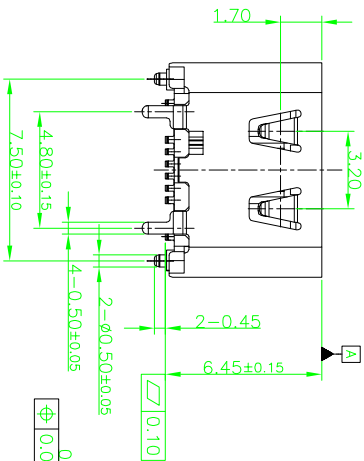
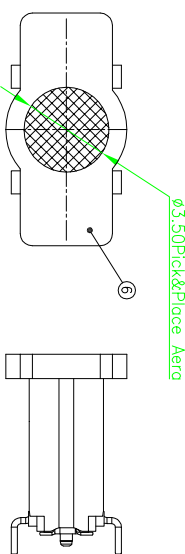
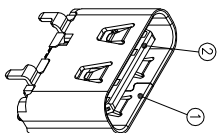
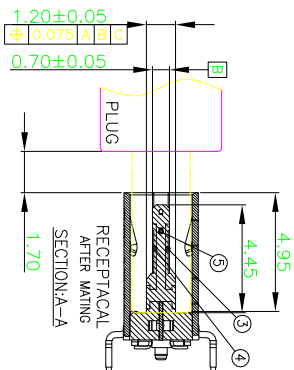
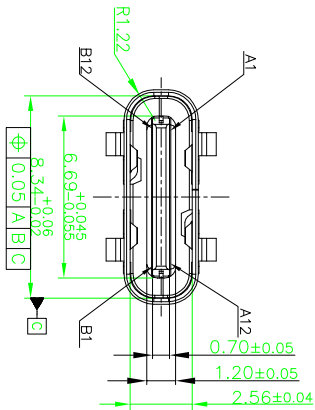

### SPECIFICATION:

1. ELECTRICAL CHARACTERISTICS:
- 1.1 CURRENT RATING: 1.5A/Pin MAX(A4,A9,B4,B9)
  - 1.2 CONTACT RESISTANCE: 40 MILLIONHM MAX.
  - 1.3 DIELECTRIC WITHSTANDING VOLTAGE: 100 VAC r.m.s
  - 1.4 INSULATION RESISTANCE: 100 MEGOHMS MIN.
2. MECHANICAL CHARACTERISTICS
- 2.1 INSERTION FORCE: 5~20N
  - 2.2 EXTRACTION FORCE: Initial:8~20N;Durability:6~20N(10000cycles);
  - 2.3 DURABILITY:10,000CYCLES
3. ENVIRONMENTAL CHARACTERISTICS
- 3.1 TEMPERATURE RANGE: -40 °C ~ 85 °C
  - 3.2 IR REFLOW: THE PEAK TEMPERATURE ON THE BOARD SHALL BE MAINTAINED FOR 10 SECONDS AT 260°C.

PIN ASSIGNMENTS:

A1	A2	A3	A4	A5	A6	A7	A8	A9	A10	A11	A12
GND	+	+	+	+	D-	D-	SBU1	+	+	+	GND
B12	B11	B10	B9	B8	B7	B6	B5	B4	B3	B2	B1
GND	+	+	+	SBU2	D-	D+	CC2	+	+	+	GND

### 产品图

PRODUCT CHART DWG

### 公差一览表

TOLERANCE UNLESS OTHERWISE			
X	±0.30	X	±5°
XX	±0.20	XX	±2°
XXX	±0.15	XXX	±1.5°

### 深圳市鑫风雷电子有限公司

Shenzhen xinfenglei Electronics Co., Ltd

NO.	DESCRIPTION	QTY.	MATERIAL	FINISH
①	SHELL	1 PCS	STAINLESS STEEL	Ni 30u" MIN. UNDER PLATED OVER ALL.
②	HOUSING	3 PCS	PA46	COLOR: BLACK
③	CONTACT A	1 SET	C18400	Ni 50u" MIN. UNDER PLATED OVER ALL. Au PLATED ON THE FUNCTIONAL AREA OF CONTACT. GOLD PLATING THICKNESS FOLLOW THE P/N FINISH SPECIFICATIONS OF THE SOLDER AREA FOLLOW THE P/N
④	CONTACT B	1 SET	C18400	COLOR: BLACK
⑤	MID PLATE	1 PCS	STAINLESS STEEL	NO SURFACE TREATMENT
⑥	CAP	1 PCS	LCP	COLOR: BLACK

单位: MM  
比例: 1:1  
日期: 2009/10/20

制图	审核	日期	制图	审核	日期
王冠	雷永健	2009/10/20	王冠	雷永健	2009/10/20

# ROHS 客户图

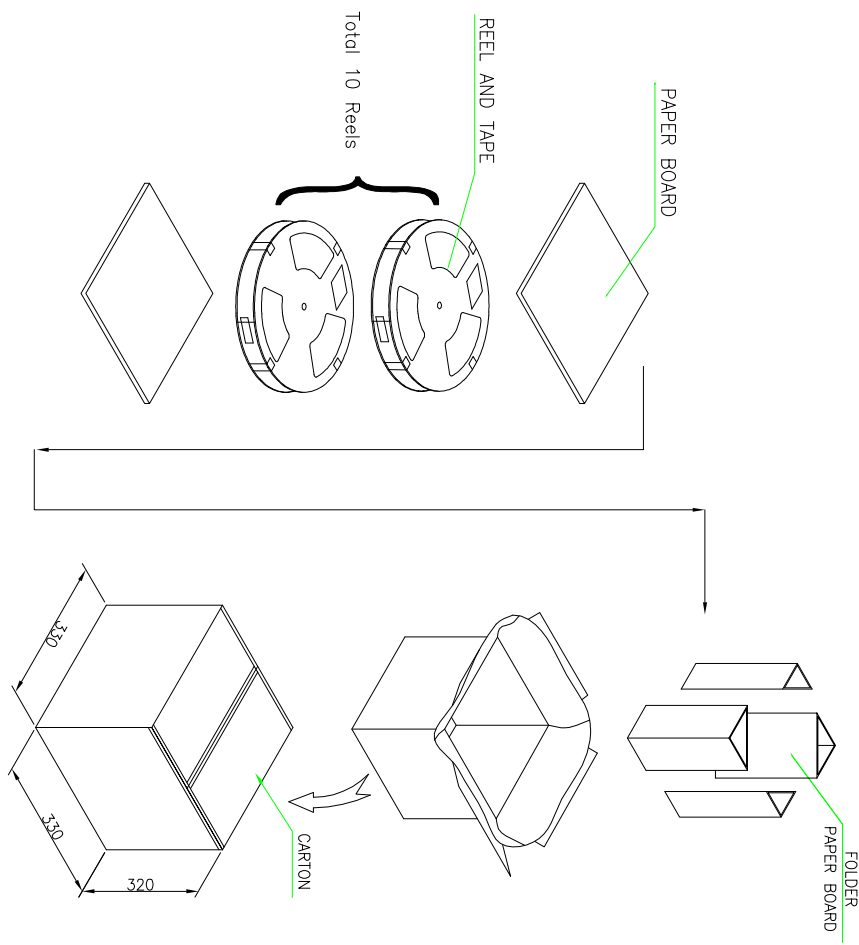
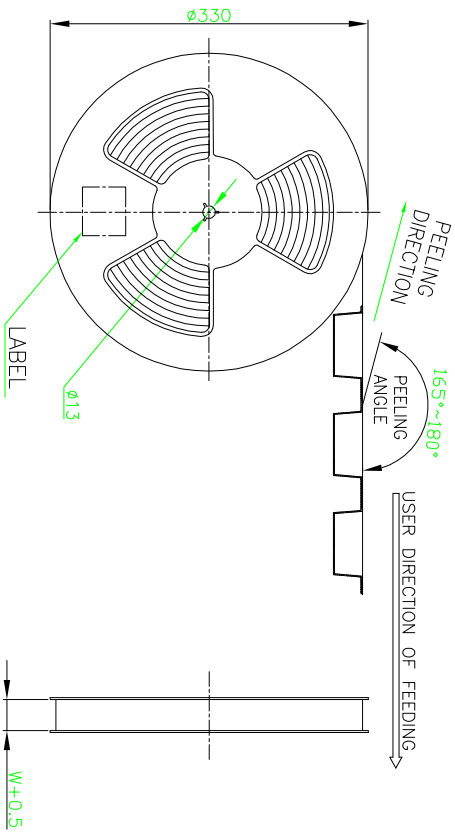
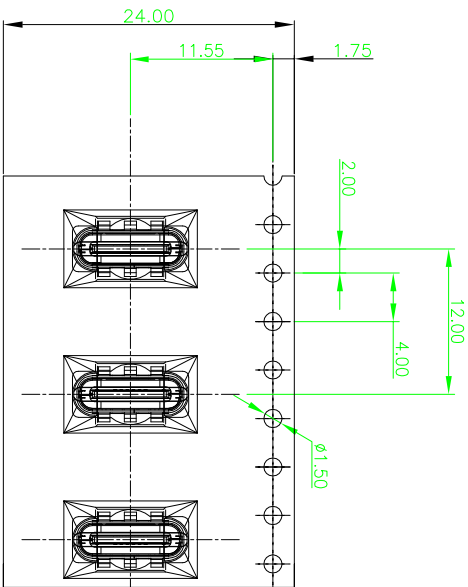
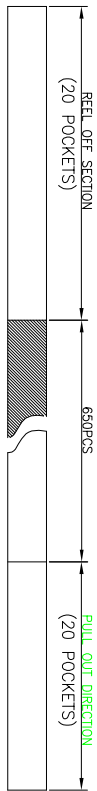

目錄 MAPX A0	變更內容 MODIFICATION NEW	日期 DATE 09-10-20
------------------	-----------------------------	------------------------

CONN. PART NO.	CONN. QTY./REEL	REEL QTY./CARTON	CONN. QTY./CARTON
01013-UCAF006-X	650	10	6500 PCS

产品图 PRODUCT CHART DWG		单位 UNITS		比例 SCALE		日期 DATE	
公差一览表 TOLERANCE UNLESS OTHERWISE		MM		1:1		2009/10/20	
X	±0.30	X'	±5°				
X	±0.25	X'	±2°				
XX	±0.20	XX'	±1°				
.XXX	±0.15	.XXX'	±0.5°				

深圳市鑫风雷电子有限公司  
Shenzhen xinfenglei Electronics Co., Ltd

制图 DRAWING	王冠 Wangguan	产品料号 PRODUCT PART NO.	01013-UCAF006-X
审核 CHKD	雷永健 Lei Yongjian	产品名称 PRODUCT NO.	Type C 16p母座立式SMT H=6.5带弹片
核准 APPD	雷永健 Lei Yongjian	联系方式 Machbox/Weib	mailto:sale1@xficomm.com www.xficom.com