

# RoHS 客户图

目錄 MAPX A0	變更內容 MODIFICATION NEW	日期 DATE 09-10-20
------------------	-----------------------------	------------------------

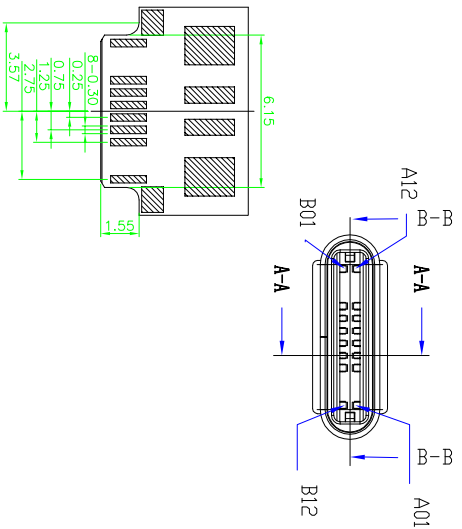
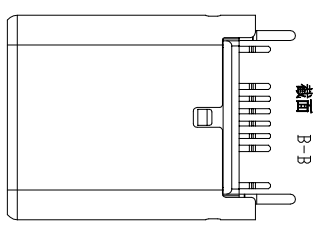
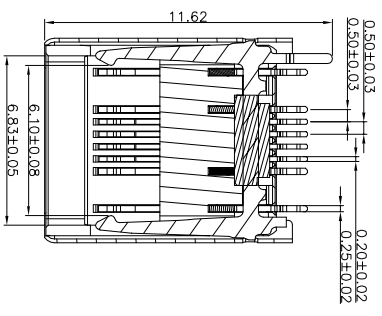
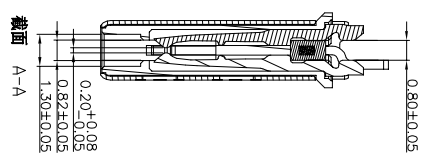
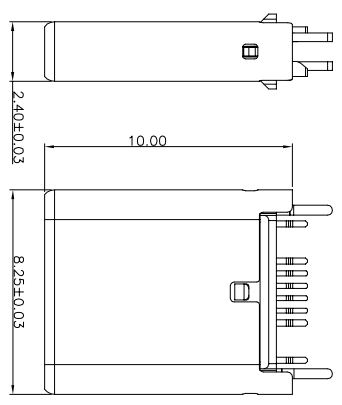
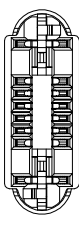

- NOTES:
- MATERIAL:
    - MOLDING: LCP UL94 V-0
    - CONTACT: COPPER ALLOY, G7025 T=0.20±0.02mm T=0.25±0.02mm
    - GOLD PLATED 1u" Min ON CONTACT AREA, 100u"
    - Min TIN (LEAD FREE) ON SOLDER AREA,
    - SHELL: SUS304-H,T=0.15±0.02mm
    - 50u" NICKEL PLATING OVER ALL.
  - MECHANICAL:
    - Card hook: SUS301-H,T=0.35±0.02mm
    - INSERTION: 5~20N.
    - EXTRACTION: 8~20N.
    - DURABILITY: 10000 CYCLES
  - ELECTRICAL:
    - CURRENT: 5A MIN FOR VBUS;
    - 0.25A MIN FOR OTHER.
    - VOLTAGE: 5VAC MAX
    - WITHSTANDING VOLTAGE: 100V AC.
    - CONTACT RESISTANCE: 40mΩ MAX.
    - INSULATION RESISTANCE: 100MΩ MIN.
  - ENVIRONMENTAL
    - TEMPERATURE RANGE -55°C ~ +85°C

TABLE : PIN DEFINE

A12	A9	A8	A7	A6	A5	A4	A1
GND	VBUS	SBU1	D-	D+	CC1	VBUS	GND
GND	VBUS	CC2	D+	D-	SBU2	VBUS	GND
B1	B4	B5	B6	B7	B8	B9	B12

RECOMMENDED P.C.B. LAYOUT (T:0.75mm)  
TOLERANCE UNSPECIFIED ±0.05mm

## 深圳市鑫风雷电子有限公司

产品图 PRODUCT CHART DWG		制图 DRAWING		王冠	产品料号 PRODUCT PART NO.	00302-UCAM003-B
公差一览表 TOLERANCE UNLESS OTHERWISE		单位 UNITS	MM	审核 CHECK	雷永健	产品名称 PRODUCT NO.
X	±0.30	X'	±5'	日期 DATE	2009/10/20	角法 VIEW
X	±0.25	X'	±2'	比例 SCALE	1:1	TYPE C 16P公头拉伸式插针式不带板
XX	±0.30	XX'	±1'	核准 APPR	雷永健	版本 VER
XXX	±0.15	XXX'	±0.5'			A0