

RoHS 客户图

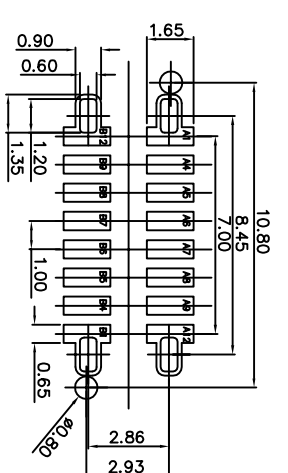
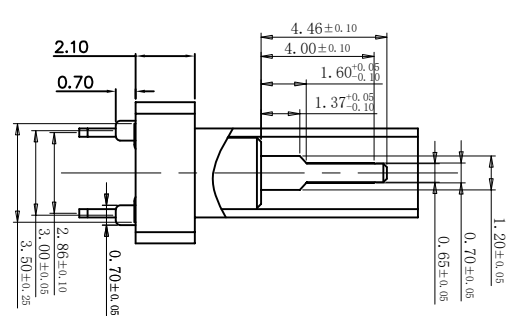
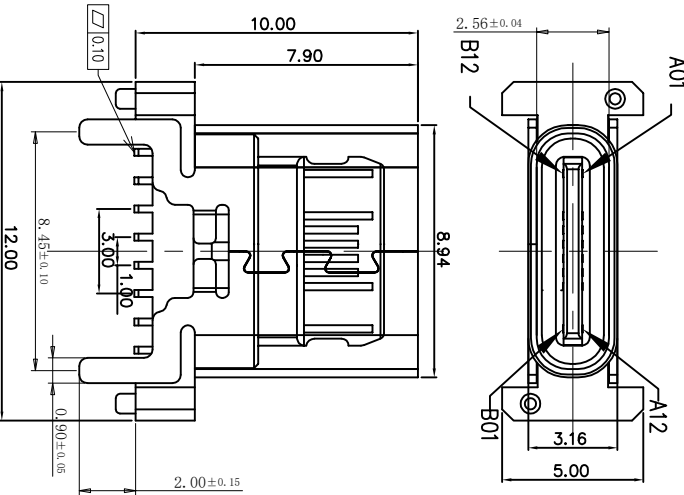
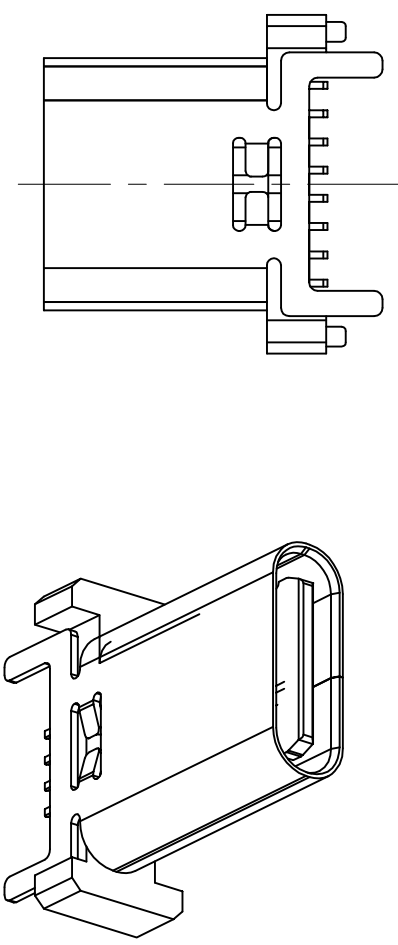

1. ELECTRICAL CHARACTERISTICS:
 - 1-1. CONTACT RESISTANCE: 30m Ω MAX.
 - 1-2. DIELECTRIC WITHSTANDING VOLTAGE: 100V AC FOR ONE MINUTE.
 - 1-3. INSULATION RESISTANCE: 100M Ω MIN. MEASURED BY 500 VDC.
2. MECHANICAL CHARACTERISTICS:
 - 2-1. INSERTION FORCE : 0.5-2.0Nf (BER.)
 - 2-2. WITHDRAWAL FORCE : 0.8-2.0Nf (BER.)
3. LIFE TEST: 10,000 CYCLES.

RECOMMENDED P.C.B. LAYOUT (T:1.00mm)
TOLERANCE UNSPECIFIED ±0.05mm

1L	Q0	B12	Q0
4L	W05	B0	W05
5L	C01	B0	S005
6L	B1	B1	W05
7L	B1	B1	W05
8L	B1	B1	W05
9L	B1	B1	W05
10L	B1	B1	W05
11L	B1	B1	W05
12L	B1	B1	W05
13L	B1	B1	W05
14L	B1	B1	W05
15L	B1	B1	W05
16L	B1	B1	W05
17L	B1	B1	W05
18L	B1	B1	W05
19L	B1	B1	W05
20L	B1	B1	W05

产品图		单位		制图		王冠		产品料号	
PRODUCT CHART DWG		MM		DRAWING		雷永健		O1002-UCAF021-X	
公差一览表		UNITS		审核		雷永健		PRODUCT PART NO.	
TOLERANCE UNLESS OTHERWISE		1:1		CHD		雷永健		TYPE O 16P单座立式SWT H=10.0	
X	±0.30	X'	±5'	XX	±0.20	XX'	±1'	XXX	±0.5'
XX	±0.25	X'	±2'	XX	±0.20	XX'	±1'	XXX	±0.5'
XX	±0.20	XX'	±2'	XX	±0.20	XX'	±1'	XXX	±0.5'
XXX	±0.15	XXX'	±0.5'	DATE	2009/10/20	核准	雷永健	画法	版本
				DATE	2009/10/20	APPD	雷永健	VIEW	VER
									A0

深圳市鑫风雷电子有限公司