

# ROHS 客户图

目錄 MAPX	变更内容 MODIFICATION	日期 DATE
A0	NEW	09-10-20

- NOTE:
1. ELECTRICAL CHARACTERISTICS:
- 1.1 RATING:  
POWER PINS COLLECTIVELY(PINS A1,A4,A9,A12,B1,B4,B9,B12 )5A  
SIGNAL PINS(OTHER):0.25A
- 1.2 CONTACT RESISTANCE: INITIAL:40 MILLIONHM MAX.  
AFTER TEST:50 MILLIONHM MAX
- 1.3 DIELECTRIC WITHSTANDING VOLTAGE: 100V AC FOR ONE MINUTE.
- 1.4 INSULATION RESISTANCE: 100 MEGOHMS MIN. MEASURED BY 100V DC.
2. MECHANICAL CHARACTERISTICS
- 2.1 PLUG INSERTION FORCE: 5~20N
- 2.2 PLUG EXTRACTION FORCE: Initial:8~20N;AFTER TEST:6~20N
- 2.3 DURABILITY:10,000CYCLES
3. DATE CODE:(Y(0,1,2,...) W(1,2,...,9,A,B.) D(1,2,...,9,A,B.))

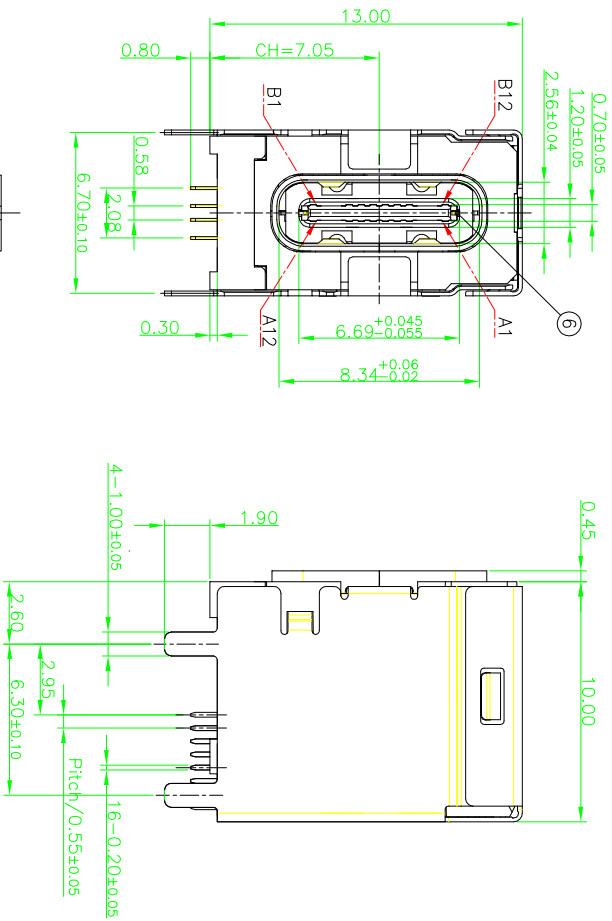
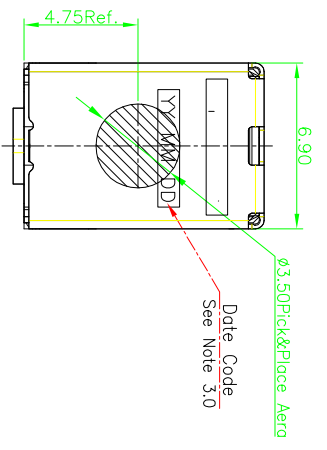

PIN ASSIGNMENTS:

A1	A2	A3	A4	A5	A6	A7	A8	A9	A10	A11	A12
GND	×	×	+	+	D+	D-	SBU1	+	+	+	GND
B12	B11	B10	B9	B8	B7	B6	B5	B4	B3	B2	B1
GND	×	×	+	+	SBU2	D-	+	+	+	+	GND

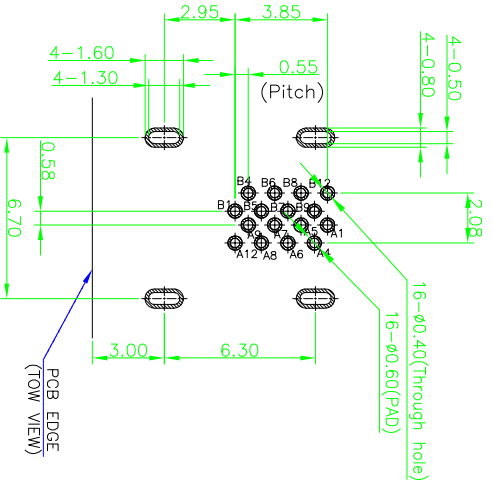

ITEM	DESCRIPTION	MATERIAL	FINISH	QTY
⑥	MID PLATE	STAINLESS STEEL	OVER ALL 0.76MICRON (30μ)MIN NICKEL PLATING	1
⑤	OUTER SHELL	STAINLESS STEEL	OVER ALL 0.76MICRON (30μ)MIN NICKEL PLATING	1
④	MAIN SHELL	STAINLESS STEEL	OVER ALL 0.76MICRON (30μ)MIN NICKEL PLATING	1
③	TERMINAL	COPPER ALLOY	GOLD PLATING 0.076MICRON (3μ)MIN ON CONTACT AREA GOLD PLATING FLASH ON SOLDERAL AREA ALL OVER 1.27 MICRON(50μ) MIN.NICKEL	16
②	IN-MOLDING	HIGH TEMP. THERMOPLASTIC	GLASS FILLED (OR EQUAL)UL 94V-0,BLACK,NO RECYCLED RESIN.	1
①	HOUSING	HIGH TEMP. THERMOPLASTIC	GLASS FILLED (OR EQUAL)UL 94V-0,BLACK,NO RECYCLED RESIN.	1

产品图

公差一览表

TOLERANCE UNLESS OTHERWISE SPECIFIED	UNIT	SCALE	DATE
X	±0.30	X'	±5'
X	±0.25	X'	±2'
XX	±0.30	XX'	±1'
XXX	±0.15	XXX'	±0.5'

深圳市鑫风雷电子有限公司  
Shenzhen xinfenglei Electronic Co., Ltd

制图 DRAWING	王冠	产品料号 PRODUCT PART NO.	01013-UCAR004-X
审核 CHECK	雷永健	产品名称 PRODUCT NO.	TYPE C 14P 母座侧插全包式
核准 APPD	雷永健	角法 VIEW	版本 VER
			A0

# RoHS 客户图

目錄 MAPX A0	變更內容 MODIFICATION NEW	日期 DATE 09-10-20
------------------	-----------------------------	------------------------

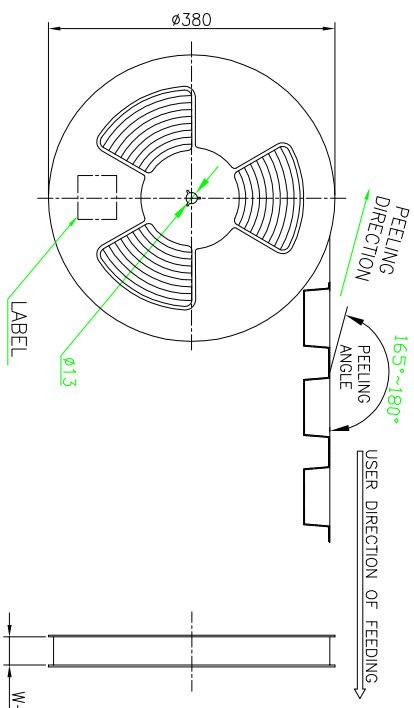
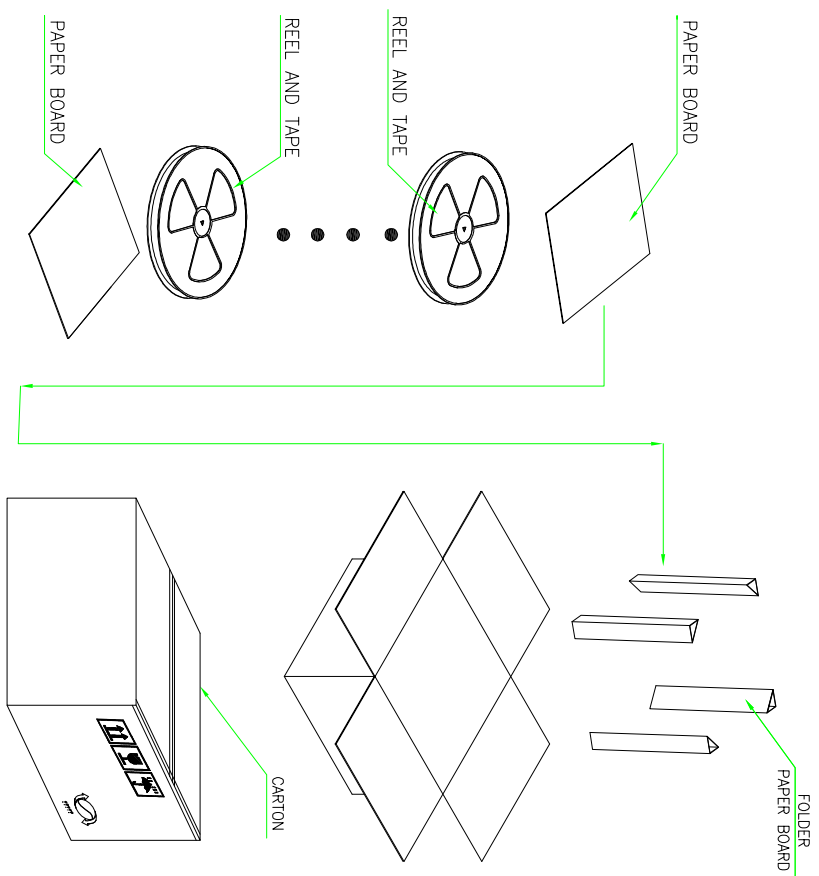
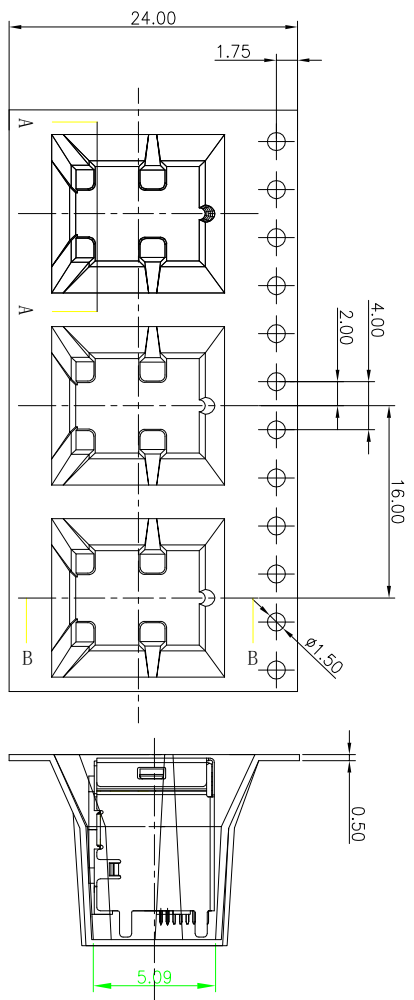
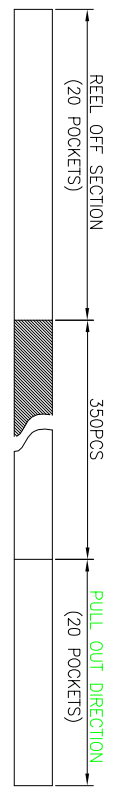

PRODUCT PACKAGING DIRECTION  
CUSTOMER TO USE DIRECTION

## 产品图

公差一览表  
TOLERANCE UNLESS OTHERWISE SPECIFIED

X	±0.30	X'	±5°
X	±0.25	X'	±2°
XX	±0.30	XX'	±1°
.XXX	±0.15	.XXX'	±0.5°

深圳市鑫风雷电子有限公司  
Shenzhen xinfenglei Electronic Co., Ltd

单位 UNITS	MM	制图 DRAWING	王冠	产品料号 PRODUCT PART NO.	01013-UCAF004-X
比例 SCALE	1:1	审核 CHKD	雷永健	产品名称 PRODUCT NO.	TYPE C 14P 母座侧插全包式
日期 DATE	2009/10/20	核准 APPD	雷永健	角法 VIEW	

CONN. PART NO.	CONN. QTY./REEL	REEL QTY./CARTON	CONN. QTY./CARTON
01013-UCAF004-X	350	8	2800 PCS