

RoHS 客户图

目錄 MAPX A0	變更內容 MODIFICATION NEW	日期 DATE 09-10-20
------------------	-----------------------------	------------------------

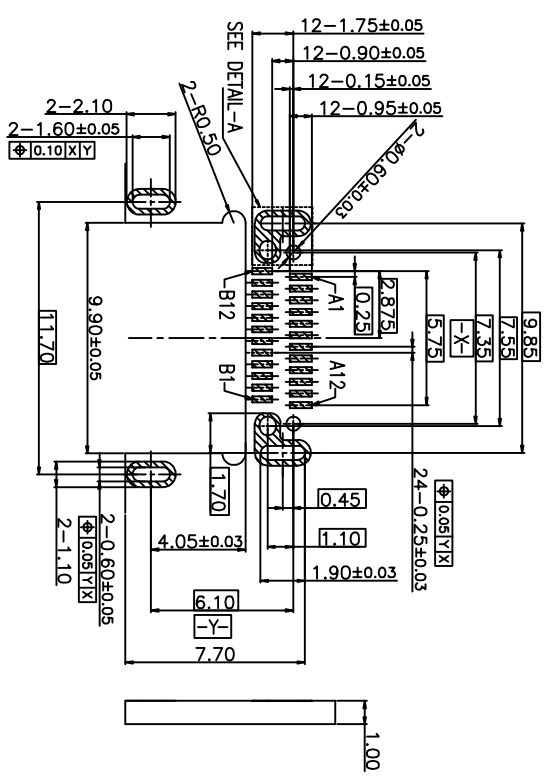
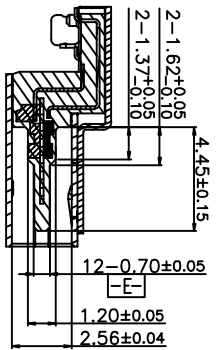
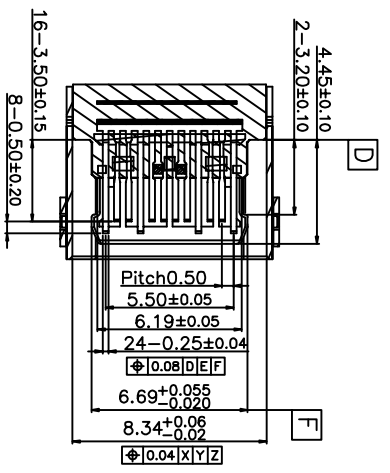
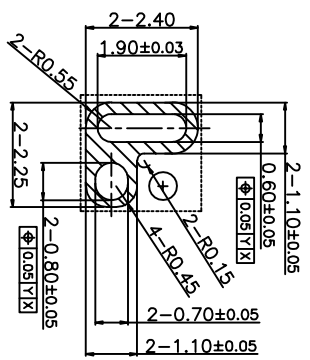
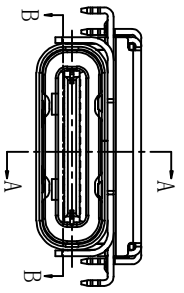

产品图

深圳市鑫风雷电子有限公司
Shenzhen xinfenglei Electronic Co., Ltd

公差一览表 TOLERANCE UNLESS OTHERWISE		单位 UNITS	MM
X	±0.30	X'	±5'
.X	±0.25	.X'	±2'
.XX	±0.30	.XX'	±1'
.XXX	±0.15	.XXX'	±0.5'
DATE	2009/10/20	DATE	
制图 DRAWING	王冠 Wangguan	产品料号 PRODUCT PART NO.	15001-UCAR001-X
审核 CHECK	雷永健 Lei Yongjian	产品名称 PRODUCT NO.	Type C 24p 母座沉板双排SMT CH=1.4
核准 APPD	雷永健 Lei Yongjian	角法 VIEW	
比例 SCALE	1:1	版本 VER	A0

RoHS 客户图

包装作业规范

包装作业图示及说明

(PACKING OPERATION DIAGRAM & INSTRUCTION)

- Put the finished product one by one into REEL packaging disk and put it in the same direction
- packaging as shown in the figure .
- 650PCS/REEL

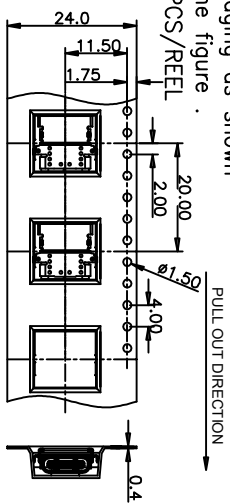

- There were 15 empty seats in the front and 15 empty seats in the rear
- Reel packaging disk filled with finished products is shown in the figure below

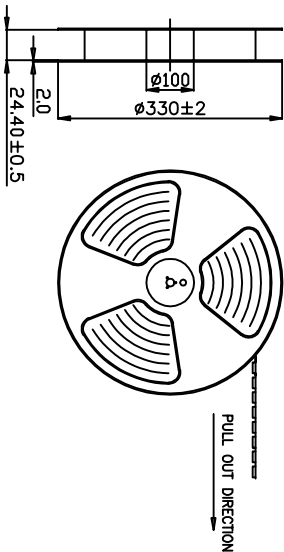

- 10 Reel/Carton
- 6500 PCS /Carton

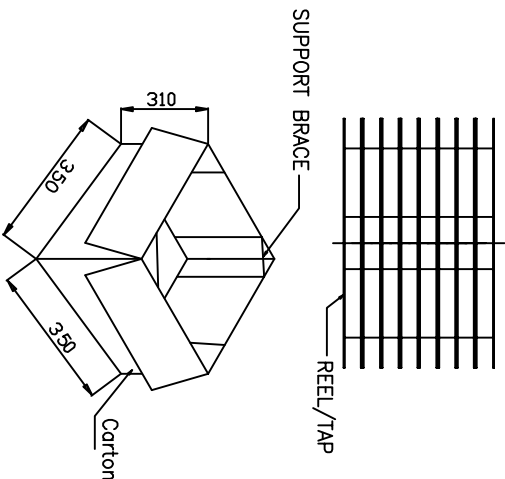

- Tape the cartons with Tape .

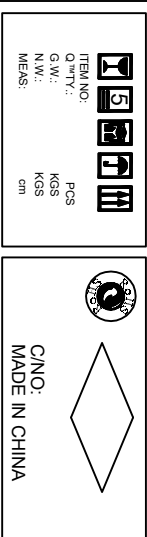

REMARK

- If there are any unfilled cartons, they must be filled with buffers .

产品图

深圳市鑫风雷电子有限公司
Shenzhen xinfenglei Electronic Co., Ltd

公差一览表 TOLERANCE UNLESS OTHERWISE		单位 UNITS		比例 SCALE		日期 DATE	
X	±0.30	X'	±5'	1:1	2009/10/20	王冠 Rongguang	产品料号 PRODUCT PART NO.
X	±0.25	X'	±2'			雷永健 Lei Yongjian	产品名称 PRODUCT NO.
XX	±0.30	XX'	±1'			雷永健 Lei Yongjian	Type C 24p母座沉板双排SMT CH=1.4
XXX	±0.15	XXX'	±0.5'				角法 VIEW