

# ROHS 客户图

目錄 MAPX	變更內容 MODIFICATION	日期 DATE
A0	NEW	09-10-20

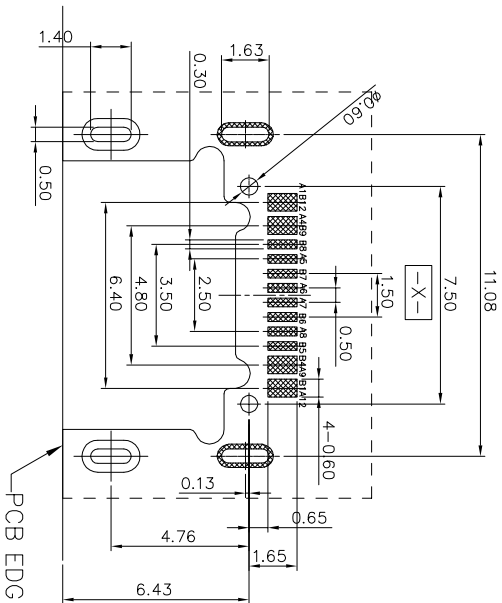
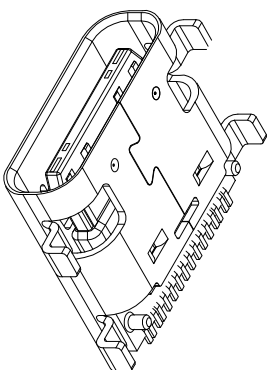
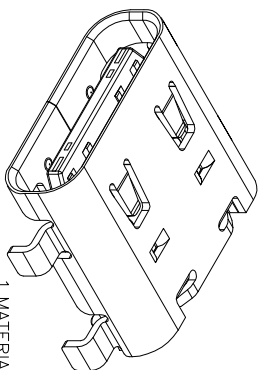
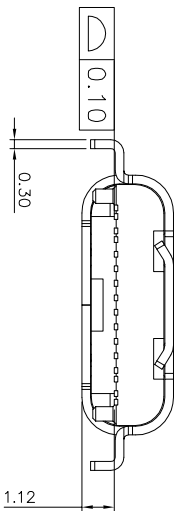
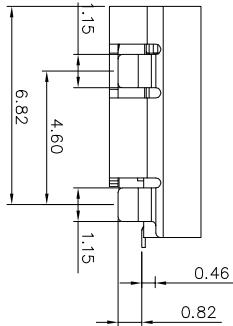
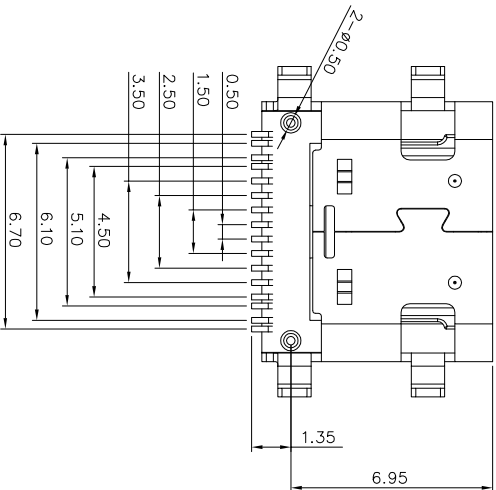
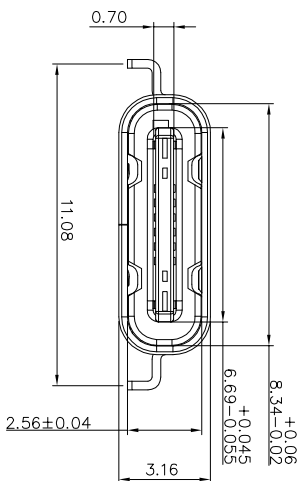
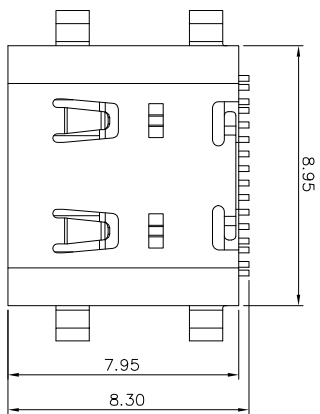

A1	GND	B12	GND
A4	VBUS	B9	VBUS
A5	CC1	B8	SBU2
A6	DP1	B7	DN2
A7	DN1	B6	DP2
A8	SBU1	B5	CC2
A9	VBUS	B4	VBUS
A12	GND	B1	GND
PIN	SIGNAL NAME	PIN	SIGNAL NAME

1. MATERIAL:  
MOLDING: LCP U194 V-0  
CONTACT: COPPER ALLOY,  
GOLD PLATED ON CONTACT AREA, 100u"  
Min. TIN (LEAD FREE) ON SOLDER AREA,  
SHELL: SUS304-H, T=0.30±0.03mm  
50u" NICKEL PLATING OVER ALL.  
SHILD: SUS304-H, T=0.12±0.03mm
  2. MECHANICAL:  
INSERTION: 5~20N,  
EXTRACTION: 8~20N,  
DURABILITY: 5000 CYCLES
  3. ELECTRICAL:  
CURRENT: 3A MIN FOR VBUS;
- VOLTAGE: 5VAC MAX  
WITHSTANDING VOLTAGE: 100V AC.  
CONTACT RESISTANCE: 40mΩ MAX.  
INSULATION RESISTANCE: 100MΩ MIN.  
4. ENVIRONMENTAL  
TEMPERATURE RANGE -55°C ~ +85°C

## 深圳市鑫风雷电子有限公司

### 产品图

PRODUCT CHART DWG

公差一览表 TOLERANCE UNLESS OTHERWISE		单位 UNITS	MM	制图 DRAWING	王冠	产品料号 PRODUCT PART NO.	23002-UCAF002-X
X	±0.30	X'	±5°	审核 CHECK	雷永健	产品名称 PRODUCT NO.	TYPE C单排16P沉板1.0 I=7.9有弹
X	±0.25	X''	±2'	核准 APPD	雷永健	角法 VIEW	版本 VER
XXX	±0.15	XXX'	±0.5°	日期 DATE			A0

# RoHS 客户图

目錄 MAPX A0	設定內容 MODIFICATION NEW	日期 DATE 09-10-20
------------------	-----------------------------	------------------------

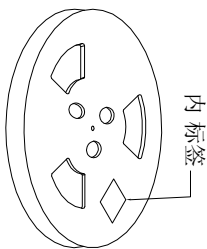

① 卷盘贴标签示意图

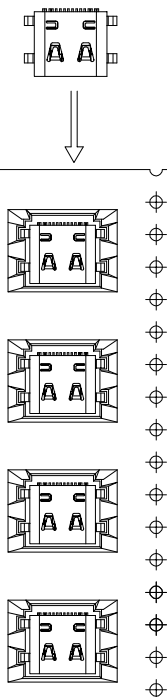

② 产品入载带示意图

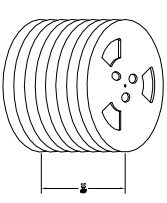

③ 10盘产品叠层示意图

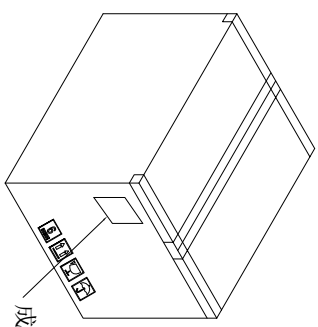

⑥ 外箱封箱示意图

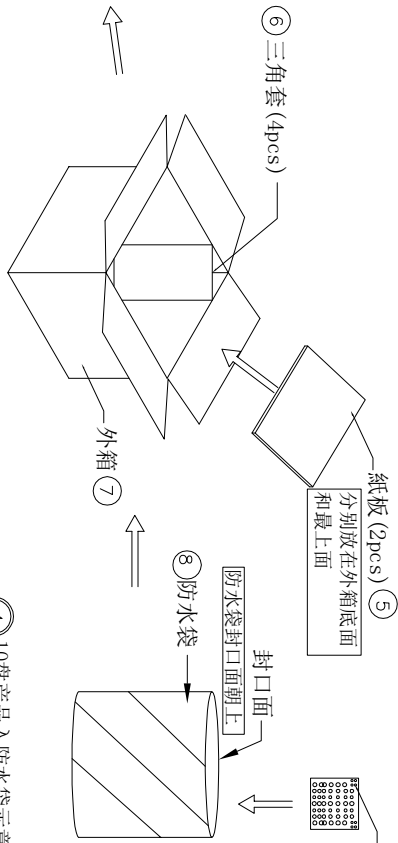

⑤ 产品入外箱示意图

④ 10盘产品入防水袋示意图

- 包装说明:
1. 将检验好的成品: SMT朝下放入载带底部; 每卷装1000PCS产品, 10000PCS/箱; 具体如图一所示
  2. 将包装好的产品: 每盘必需贴上内标签; 具体如图二所示
  3. 将贴好内标签的产品每8盘叠一层装入防水袋中并加一包干燥剂; 装好后将防水袋封好; 具体如图三图四所示
  4. 先将1pcs平卡放入纸箱底部; 然后将装好产品的防水袋装入纸箱中; 防水袋热熔封口, 封口面需朝上; 并将4PCS三角套分别装入4个角; 如图五所示
  5. 装好后将1pcs平卡放入纸箱最上面并封好纸箱及贴好相关标签; 具体如图六所示;
  6. 载带前面留30PCS空格, 后面留20PCS空格
  7. COVER与CARRY剥离力: 50-125g, 速度: 300mm/分钟左右, 剥离角度: 165°-180°

## 产品图

## 深圳市鑫风雷电子有限公司

公差一览表 TOLERANCE UNLESS OTHERWISE		单位 UNITS	MM	制图 DRAWING	王冠	产品料号 PRODUCT PART NO.	23002-UCAF002-X
X	±0.30	X'	±5°	审核 CHKD	雷永健	产品名称 PRODUCT NO.	TYPE C单排16P沉版1.0 L=7.9有弹
XX	±0.25	XX'	±2'	核准 APPD	雷永健	角法 VIEW	版本 VER
XXX	±0.15	XXX'	±1'	日期 DATE			A0