

RoHS

客户图

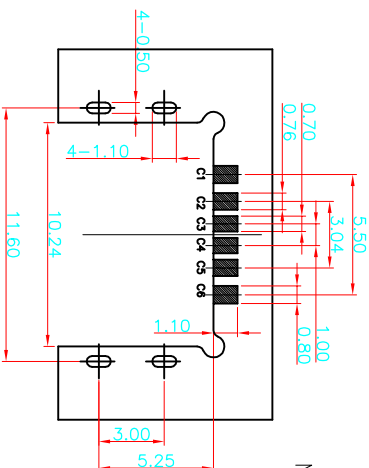
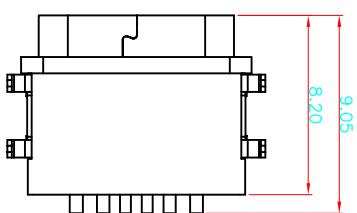
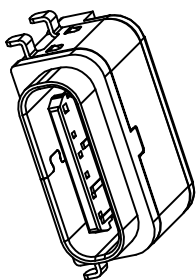

RECOMMENDED P.C.B. LAYOUT
TOLERANCE UNSPECIFIED ±0.05mm

- NOTES:
SPECIFICATION:
- CURRENT RATING: 3.0A MAX
 - VOLTAGE: 100 VAC
 - TEMPERATURE RANGE: -30 °C ~ 85 °C
 - CONTACT RESISTANCE: 40 MILLIONHM MAX
 - INSULATION RESISTANCE: 100 MEGOHMS MIN.
 - INSERTION FORCE: 5N~20N
 - UNMATING FORCE: 8N~20N
 - DURABILITY: 10,000 CYCLES
 - WATER PROOFNESS: THIS PRODUCT IS BASED ON IPX7.

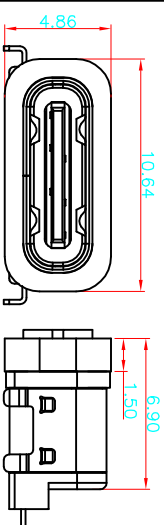
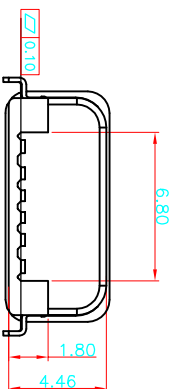
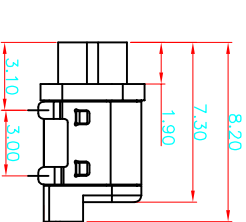
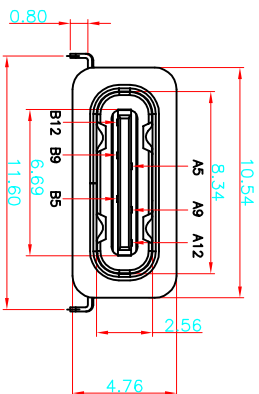

加防水圈示意图

备注:

NO.	料号	备注
1	AA0B010-078	不带硅胶
2	AA0B010-080	带硅胶

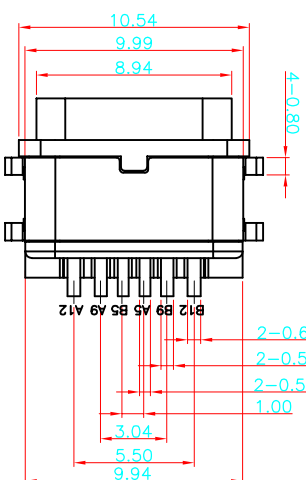

NO.	DESCRIPTION	MATERIAL	REMARKS	QTY
5	防水圈	硅胶	BLACK	1PCS
4	SHELL	STAINLESS STEEL	NI Plated	1PCS
3	SHIELDING PLATE	STAINLESS STEEL	NI Plated	1PCS
2	CONTACT	COPPER ALLOY	TIN/AU/NI Plated	1SET
1	HOUSING	HIGH TEMPERATURE PLASTIC	BLACK	1PCS

产品图

深圳市鑫风雷电子有限公司
Shenzhen xinfenglei Electronic Co., Ltd

PIN ASSIGNMENT:

PIN NO	A1&B12	A4&B9	A5	B5	A9&B4	A12&B1
SIGNAL NAME	GND	VBUS	CC1	CC2	VBUS	GND
PCB PAD NO.	C1	C2	C3	C4	C5	C6

公差一览表

TOLERANCE UNLESS OTHERWISE	X	X'	X''	X'''
XX	±0.30	±0.25	±0.30	±0.15
XX'	±0.30	±0.25	±0.30	±0.15
XX''	±0.30	±0.25	±0.30	±0.15
XX'''	±0.30	±0.25	±0.30	±0.15

单位: MM
比例: 1:1
日期: 2009/10/20

制图: 王冠
审核: 雷永健
产品料号: 00101-UCAF012-B

DATE	SCALE	DATE	SCALE	DATE	SCALE
2009/10/20	1:1	2009/10/20	1:1	2009/10/20	1:1