

# RoHS 客户图

目錄 MAPX A0	變更內容 MODIFICATION NEW	日期 DATE 09-10-20
------------------	-----------------------------	------------------------

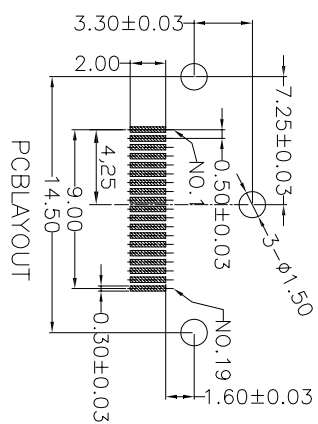
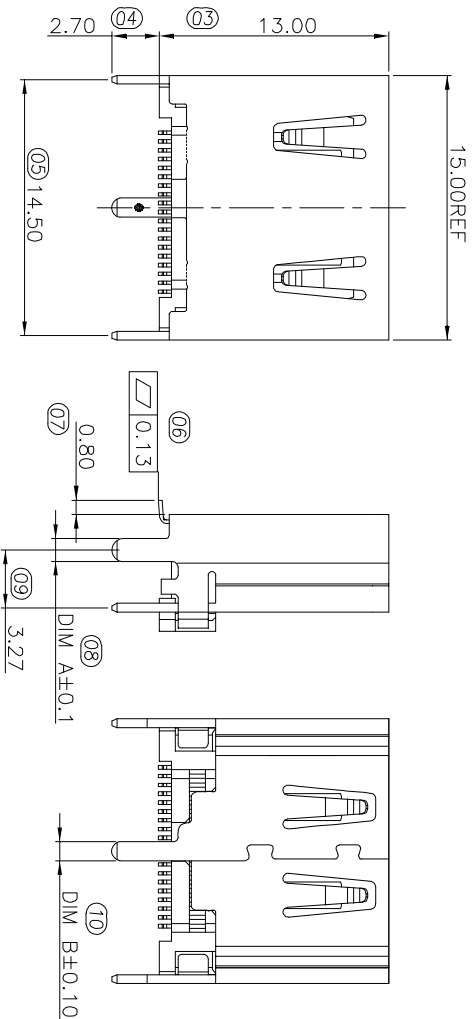
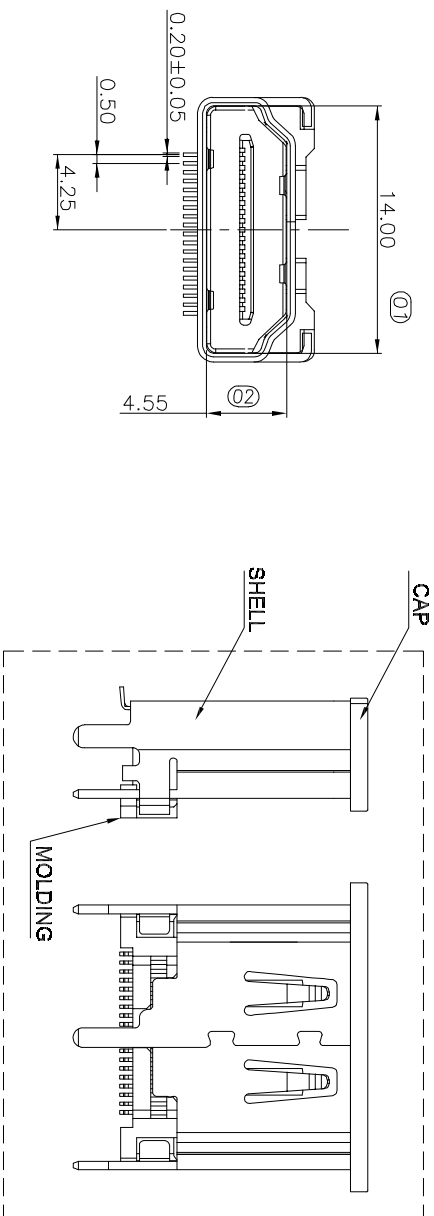

## NOTE:

- MECHANICAL CHARACTERISTICS
  - INSERTION FORCE: 44.1N MAX
  - EXTRACTION FORCE: 9.8N MIN, 39.2N MAX
  - MOTING CYCLE:10000 CYCLES
  - CONTACT PULL OUT FORCE: 1.96N/PIN MIN
  - SCREW TIGHTENING TORQUE:3.5±0.5KG
- ELECTRICAL CHARACTERISTICS
  - RATING CURRENT: 0.5A
  - RATING VOLTAGE: 40V
  - CONTACT RESISTANCE: 10 MILLOHMS OHMS MAX
  - INSULATION RESISTANCE:
    - a, UNMATED: 100M OHMS MIN AT 500 VDC
    - b, MATED: 10M OHMS MIN AT 150 VDC
  - DIELECTRIC WITHSTANDING VOLTAGE: 300V AC/1MINUTE
  - OPERATING TEMPERATURE: -20°C--+85°C
  - STORAGE TEMPERATURE: -20°C--+65°C

## 产品图

## 深圳市鑫风雷电子有限公司

公差一览表 TOLERANCE UNLESS OTHERWISE SPECIFIED		单位 UNITS	MM	制图 DRAWING	王冠	产品料号 PRODUCT PART NO.	17005-HIDAF006-X
X	±0.30	X'	±5'	审核 CHECK	雷永健	产品名称 PRODUCT NO.	HDMI A型母座180度DIP H=3.0MM
.XX	±0.25	.X'	±2'	核准 APPRO	雷永健	角法 VIEW	
.XXX	±0.15	.XXX'	±0.5'	日期 DATE	2009/10/20	版本 VER	A0