

ROHS 客户图

1 2 3 4 5 6 7 8 9 10

目錄 MAPX	變更內容 MODIFICATION	日期 DATE
A0	NEW	09-10-20

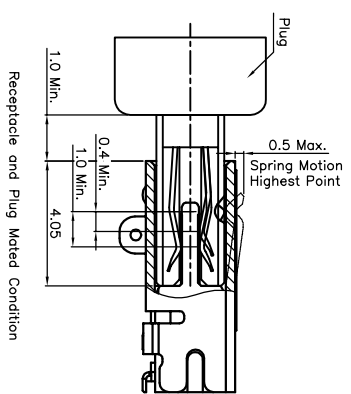
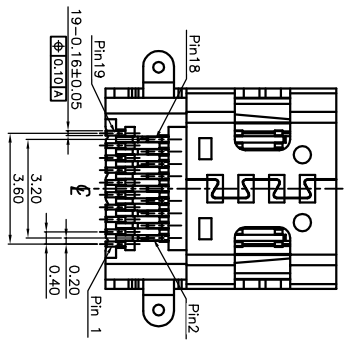
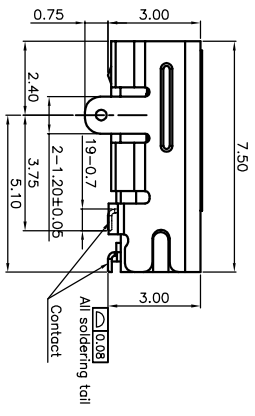
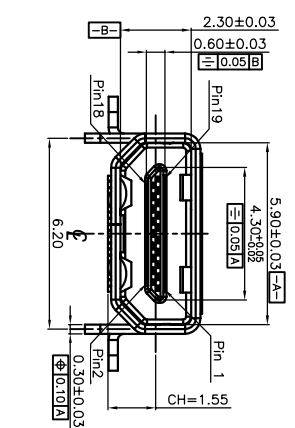
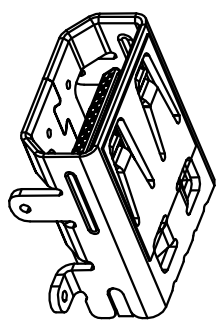
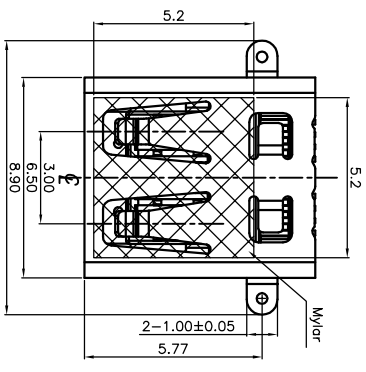

- Notes:
- Materials
 - Housing: LCP+30% G/F, Black, U194 V-0;
 - Contact: Phosphor Copper (C5191), Gold Plating at mating area, Matte Tin or Au Plating at solder tail, all over Nickel;
 - Shell: Phosphor Copper (C5191);
 - Ratings
 - Current Rating: 0.3A ;
 - Operating Temperature: -40期 ~ 85期;
 - Electrical Requirement:
 - LLCR: Excluding Conductor Resistance 10mΩ Max.(Target design value), Contact: 30mΩ Max. changed (Final), Shell: 50mΩ Max. Changed (Final);
 - Dielectric Withstanding Voltage: 150V AC (RMS) for 1 minute (Mated), 250V AC (RMS) for 1 minute (Unmated);
 - Insulation Resistance: 10MΩ Min. @ 150V DC (Mated), 100MΩ Min. @ 500V DC (Unmated);
 - Mechanical Performance:
 - Insertion force: 44.1N (4.5Kgf) Max.;
 - Withdrawal force: 4.9~25N (0.5~2.5Kgf);
 - Durability life: 5,000 Cycles;
 - IR Reflow: the peak temperature on board shall be maintained for 10 seconds at 260期.

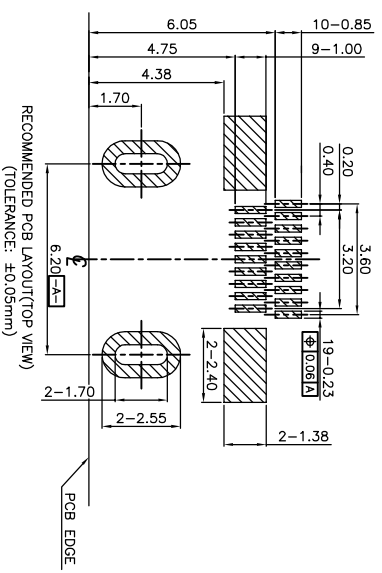

PIN	Signal Assignment
1	Hot Plug Detect
2	Utility
3	TMDS Data2+
4	TMDS Data2 Shield
5	TMDS Data2-
6	TMDS Data1+
7	TMDS Data1 Shield
8	TMDS Data1-
9	TMDS Data0+
10	TMDS Data0 Shield
11	TMDS Data0-
12	TMDS Clock+
13	TMDS Clock Shield
14	TMDS Clock-
15	CEC
16	DDC/CEC Ground
17	SCL
18	SDA
19	+5V Power

产品图

公差一览表		单位	MM	制图	王冠	产品料号	16003-HDDP001-X
TOLERANCE UNLESS OTHERWISE	UNITS	UNITS		DRAWING		PRODUCT PART NO.	
X	±0.30	X	±5°	审核	雷永健	产品名称	HDMI Type D 19Pin
X	±0.25	X	±2°	核准	雷永健	版本号	板上型CH=1.55,双孔SMT,外壳前盖面
XX	±0.30	XX	±1°	日期	2009/10/20	角法	⊕ ⊖
XXX	±0.15	XXX	±0.5°	DATE		版本	A0

ROHS

客户图

目錄 MAPX A0	變更內容 MODIFICATION NEW	日期 DATE 09-10-20
------------------	-----------------------------	------------------------

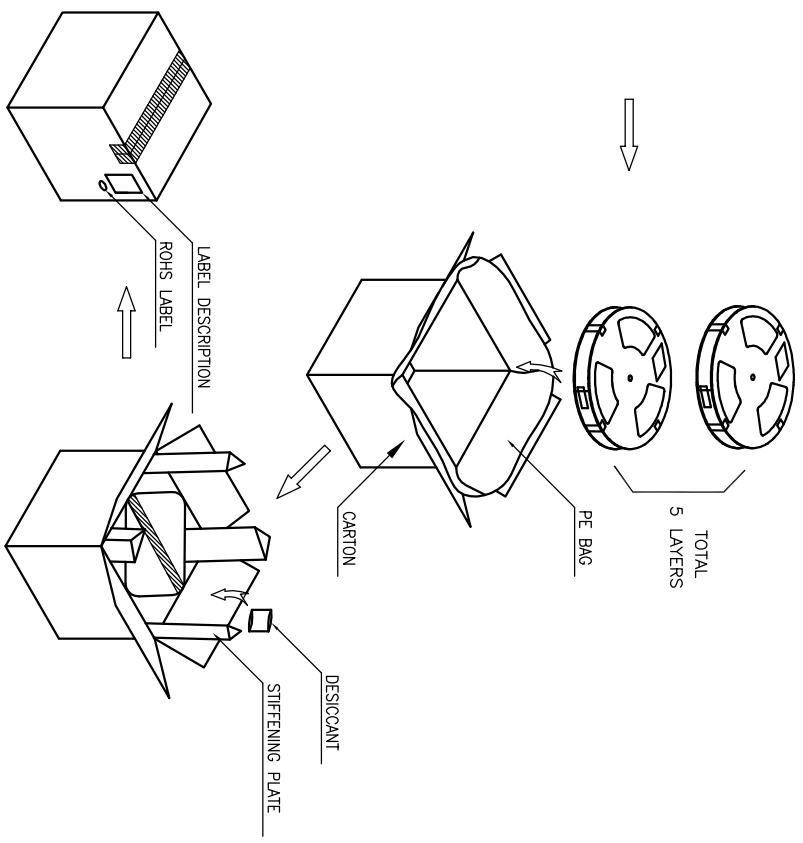
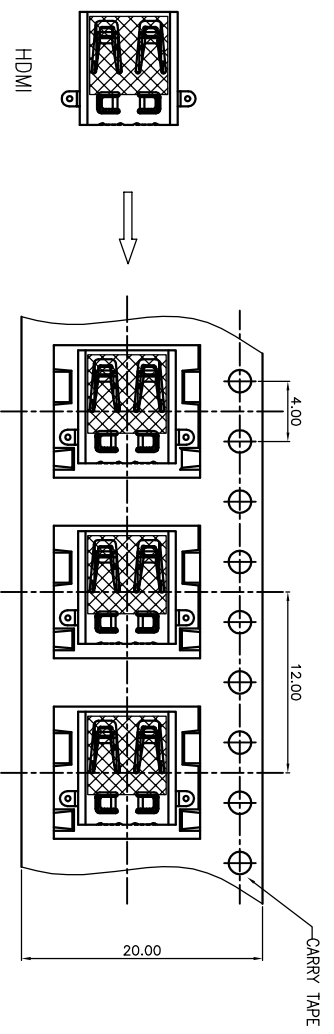
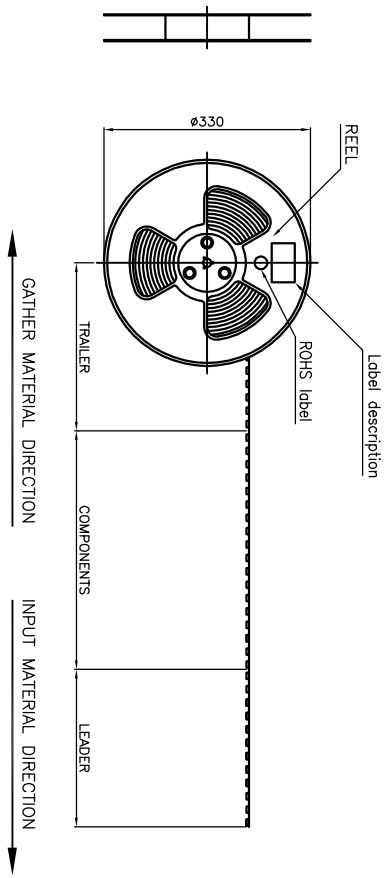

- Notes:
1. The start and end of each reel, based on the actual quantity, reserved 10--15pcs space;
 2. Peel off force of top tape: 10g~130g, peel deg.:165#175?
 3. peel speed: 250~300mm/min;
 4. Carton size: 350*350*135mm.
4. QTY: 1200pcs/reel, 5reel/carton, total 6000pcs/carton.

产品图

深圳市鑫风雷电子有限公司

公差一览表 TOLERANCE UNLESS OTHERWISE		单位 UNITS	MM	制图 DRAWING	王冠	产品料号 PRODUCT PART NO.	16003-HDDH001-X
X	±0.30	X'	±5'	审核 CHECK	雷永健	产品名称 PRODUCT NO.	HDMI Type D 19Pin, 板上型CH=1.55, 板贴型SMT, 外壳加焊锡膏
.XX	±0.25	.X'	±2'	核准 APPD	雷永健	角法 VIEW	版本 VER
.XXX	±0.15	.XXX'	±0.5'	日期 DATE	2009/10/20		A0