

ROHS 客户图

Date Code:
YY MM DD
DATE
MONTH
YEAR

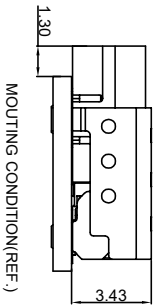
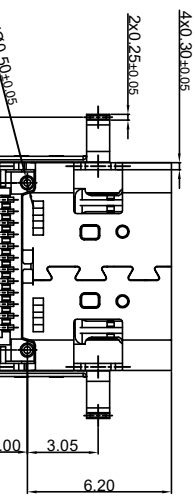
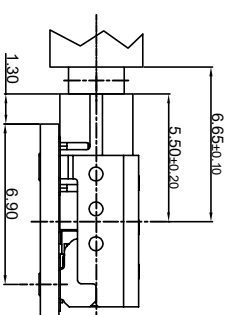
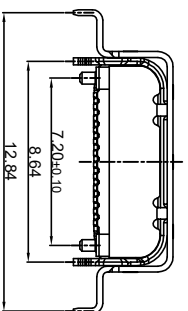
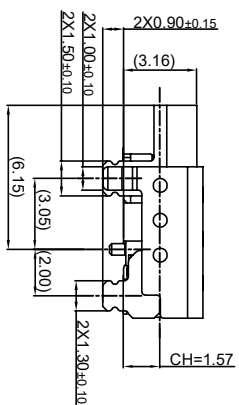
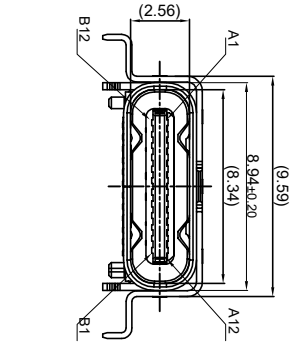
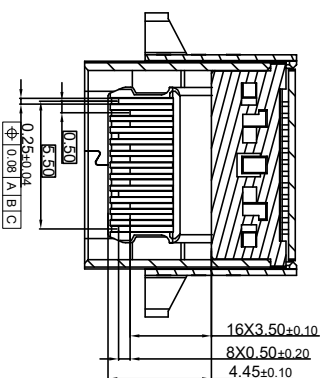
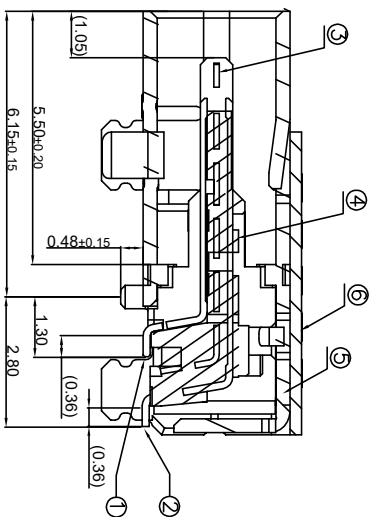
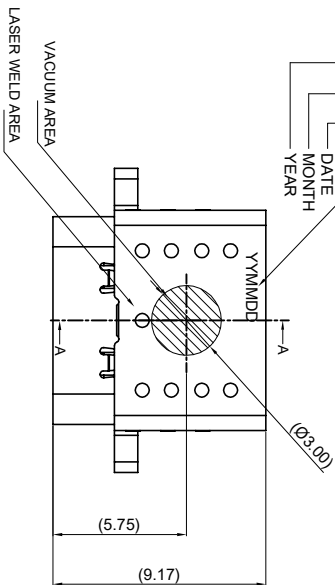

Pin定义:

A1	A2	A3	A4	A5	A6	A7	A8	A9	A10	A11	A12
GND	TX1+ TX1-	Vbus	CC1	D+	D-	SBU1	Vbus	RX2-	RX2+	GND	GND
B12	B11	B10	B9	B8	B7	B6	B5	B4	B3	B2	B1

ITEM	DESCRIPTION	QTY	MATERIAL	FINISH	REMARK
6	OUT SHELL	1	STAINLESS STEEL	NICKEL PLATING	
5	INT SHELL	1	STAINLESS STEEL	NICKEL PLATING	
4	MAIN HOUSING	1	HIGH TEMPERATURE		COLOR:BLACK
3	MID PLATE	1	STAINLESS STEEL		
2	BOTTOM TERMINAL	1	COPPER ALLOY		
1	TOP TERMINAL	1	COPPER ALLOY		
					WATING SURFACE GOLD FLASH, SMT NICKEL OVERBALL
					SOLDER FLASH GOLD FLASH, SMT NICKEL OVERBALL

产品图
PRODUCT CHART DWG

公差一览表
TOLERANCE UNLESS OTHERWISE

X	±0.30	X'	±5'
XX	±0.25	X''	±2'
XXX	±0.30	XX'	±1'
XXX	±0.15	XXX'	±0.5'

单位名称: MM
比例: 1:1
日期: 2009/10/20

制图: 王冠
审核: 雷永健
核准: 雷永健

产品料号: 11016-UCAF003-B
产品名称: TYPE C 24P母接板上双壳双磁 L=9.17外充脚长0.9

Shenzhen xinfenglei Electronic Co., Ltd

目錄 MAPX	变更内容 MODIFICATION	日期 DATE
A0	NEW	09-10-20

目錄 MAPX	修改內容 MODIFICATION	日期 DATE
A0	NEW	09-10-20

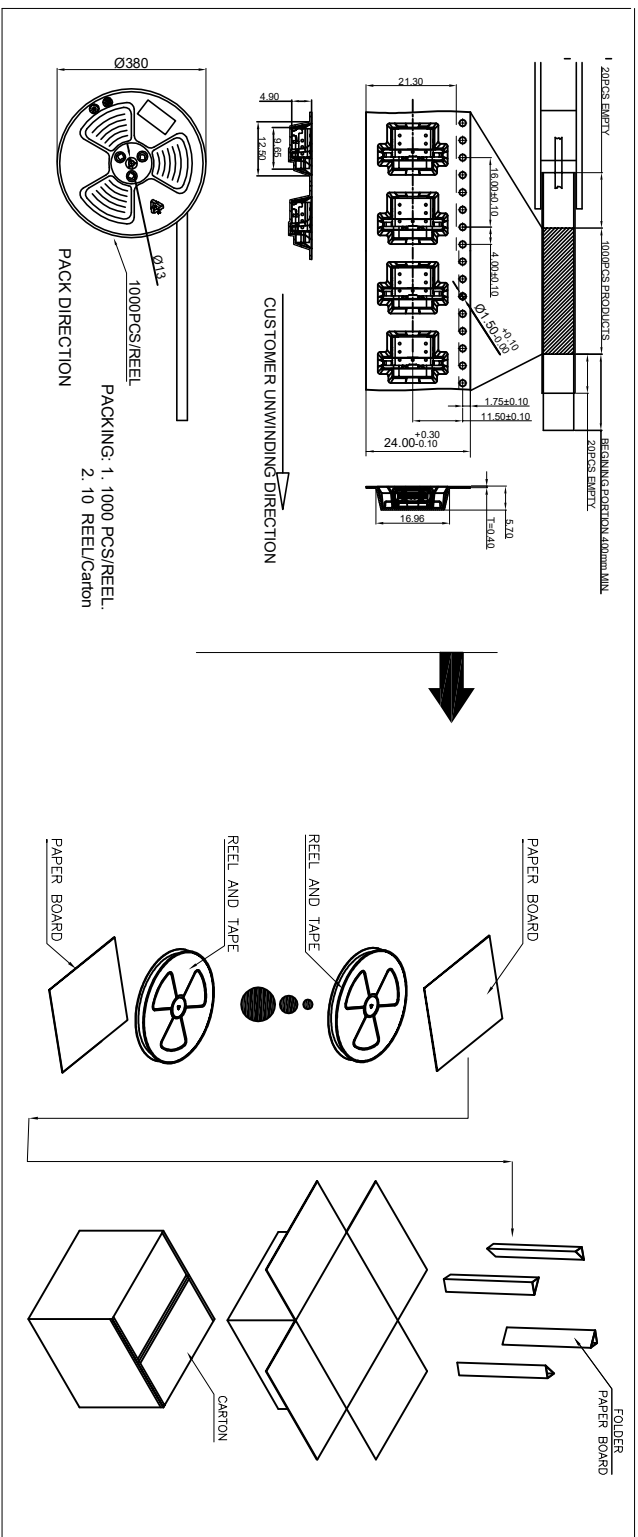

- NOTE/注释:
1. SPECIFICATION/规格:
 - 1.1 Rated current (额定电流) : 5.0 A
 - 1.2 Voltage rating (额定电压) : 5V AC
 - 1.3 Contact Resistance (接触阻抗) : 40 m Ω Max.
 - 1.4 Insulation Resistance (绝缘阻抗) : 100M Ω Min.
 - 1.5 Withstanding voltage (耐电压) : 100 VAC/minute
 - 1.6 Mating force (插入力) : 5~20N.
 - 1.7 Umating force (拔出力) : 8~20N.
 - 1.8 Durability Cycle(寿命循环):10,000 cycle
 - 1.9 Operating temperature (工作温度) : -40°~+85°

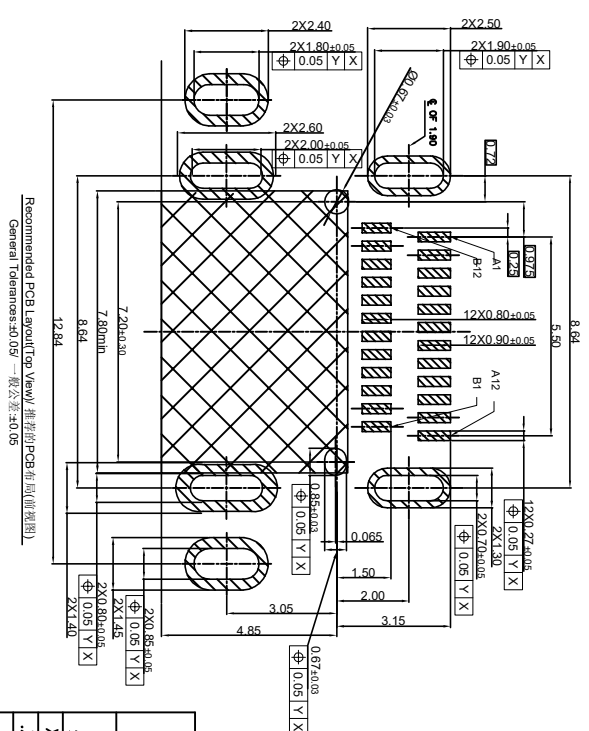

产品图 PRODUCT CHART DWG		深圳市鑫风雷电子有限公司 Shenzhen xinfenglei Electronic Co., Ltd			
公差一览表 TOLERANCE UNLESS OTHERWISE		单位 UNITS	制图 DRAWING	审核 CHECK	产品料号 PRODUCT PART NO.
X	±0.30	MM	王冠	雷永健	11016-UCAF003-B
X	±0.25	X	王冠	雷永健	
XX	±0.30	XX	王冠	雷永健	
XXX	±0.15	XXX	王冠	雷永健	
		比例 SCALE	日期 DATE	产品名称 PRODUCT NO.	角法 VIEW
		1:1	2009/10/20		
				版本 VER	
				A0	