

1 2 3 4 5 6 7 8 9 10

# RoHS

# 客户图

目錄 MAPX	變更內容 MODIFICATION	日期 DATE
A0	NEW	09-10-20

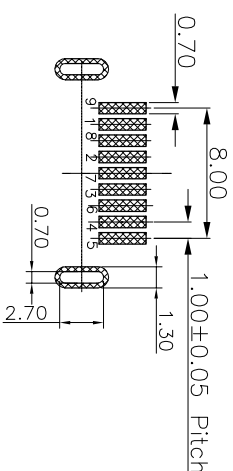
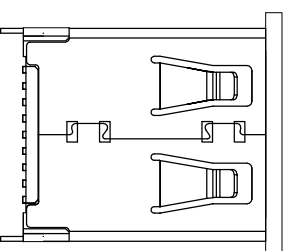
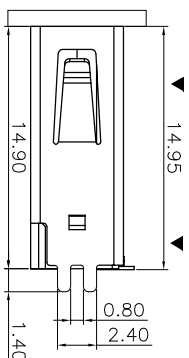
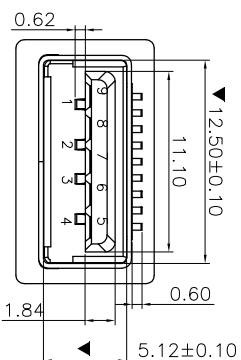
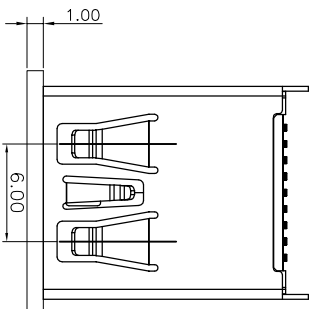
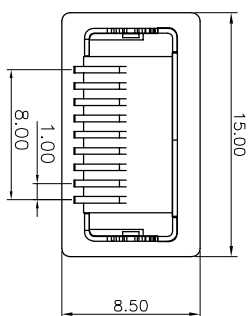

RECOMMENDED P.C.B LAYOUT(TOP VIEW)

PIN NO.	PIN 1	PIN 2	PIN 3	PIN 4
SIGNAL NAME	V BUS	D-	D+	GND
REMARK	USB 2.0 CONTACT PINS			

PIN NO.	PIN 5	PIN 6	PIN 7	PIN 8	PIN 9
SIGNAL NAME	STDA_SSRX-	STDA_SSRX+	GND_DRAIN	STDA_SSTX-	STDA_SSTX+
REMARK	USB 3.0 CONTACT PINS				

## 产品图

PRODUCT CHART DWG

# 深圳市鑫风雷电子有限公司

公差一览表 TOLERANCE UNLESS OTHERWISE		单位 UNITS	制图 DRAWING	产品料号 PRODUCT PART NO.
X	±0.30	X'	王冠	00505-13AR023-B
X	±0.25	X'	审核 雷永健	产品名称 USB3.0 AF 180度SMT短直脚无边H=15.0
.XX	±0.30	.XX'	核准 雷永健	角法 VIZIEW
.XXX	±0.15	.XXX'	核推	版本 A0

比例 SCALE	日期 DATE
1:1	2009/10/20