

1 2 3 4 5 6 7 8 9 10

**RoHS**

**客户图**

目錄 MAPX	變更內容 MODIFICATION	日期 DATE
A0	NEW	09-10-20

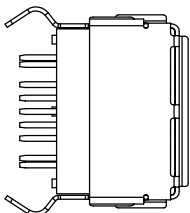
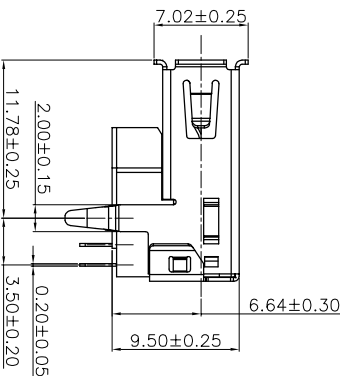
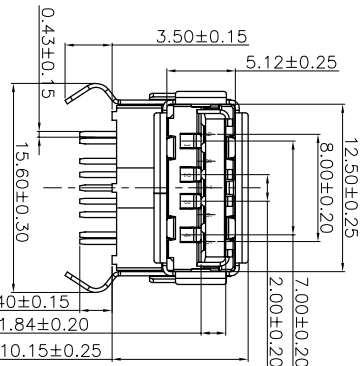
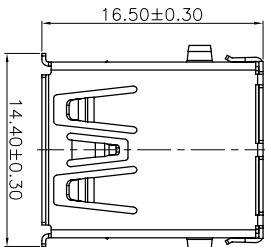

- SPECIFICATIONS:**
- 1.0 Electrical Performance:
    - 1.1 Contact current Rating:
      - 1.80 Amperes for VBUS and GND contacts
      - 0.25 Amperes for all other contacts
    - 1.2 Dielectric Withstanding Voltage:AC 100V/minute
    - 1.3 Insulation resistance:100M ohms Min
    - 1.4 Contact Resistance:
      - 30m ohm Max for VBUS and GND contacts
      - 50m ohm Max for all other contacts
    - 1.5 Voltage Rating : 30 Vac (rms)
  - 2.0 Mechanical Performance:
    - 2.1 Mating Force:35N Max
    - 2.2 Unmating Force:10N~25N;
    - 2.3 Durability:1500 cycles
  - 3.0 Environmental Performance:
    - 3.1 Temperature Range:
      - 3.1.1 Operating Temperatures:-20°C TO +85°C.
      - 3.1.2 Storage Temperatures: -45°C TO +60°C.
    - 3.2 Salt Spray 24h for contact gold&shell Nickel
  - 4.0 MATERIAL:
    - 4.1 Housing:PA9T,Blue300C See table UL94 V-0
    - 4.2 Contact:2.0 Contacts C5191&3.0 Contacts C2680
    - 4.3 Shell:SUS
  - 5.0 PLATING:
    - 5.1 Contact: Au Plated on contact area
    - 5.2 Shell:Nickel 50u"Min Plated underplating over all.

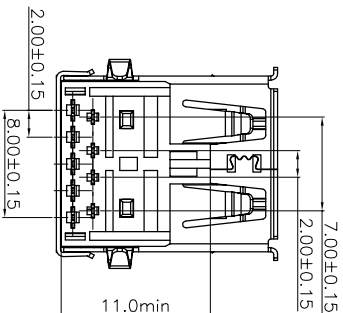

**产品图**

**深圳市鑫风雷电子有限公司**

公差一览表 TOLERANCE UNLESS OTHERWISE SPECIFIED		单位 UNITS	MM	制图 DRAWING	王冠	产品料号 PRODUCT PART NO.	11005-U3AF009-X
X	±0.30	X'	±5'	审核 CHECK	雷永健	产品名称 PRODUCT NO.	USB 3.0 AF 90度弯脚有边加高H=9.5
.XX	±0.25	.X'	±2'	核准 APPD	雷永健	角法 VIEW	⊕ ⊖
.XXX	±0.15	.XXX'	±0.5'	日期 DATE		版本 VER	A0
					2009/10/20		