

1

2

3

4

5

6

7

8

9

10

RoHS 客户图

目錄 MAPX	變更內容 MODIFICATION	日期 DATE
A0	NEW	09-10-20

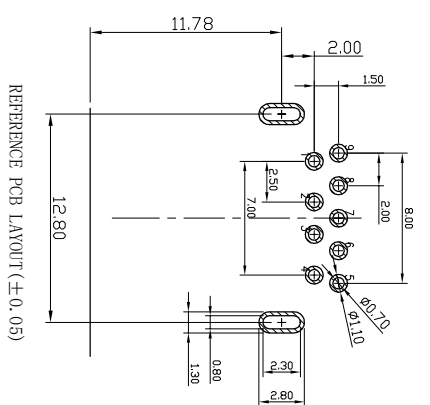
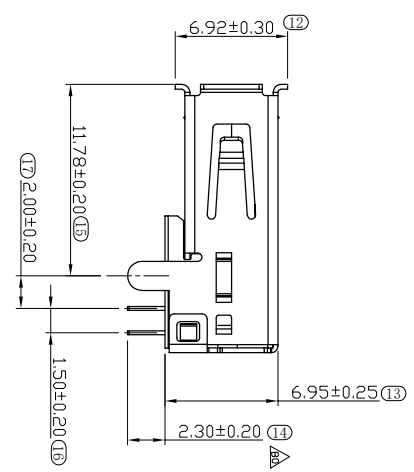
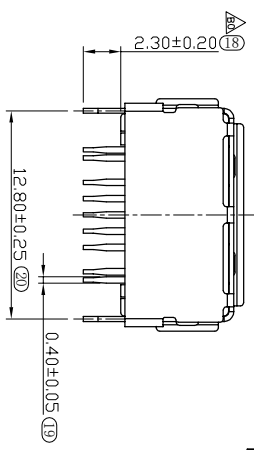
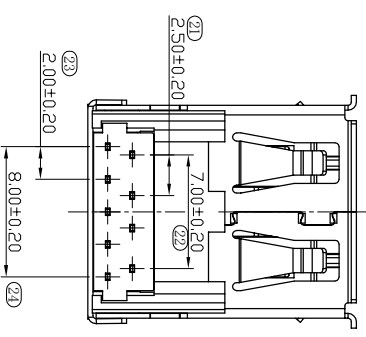
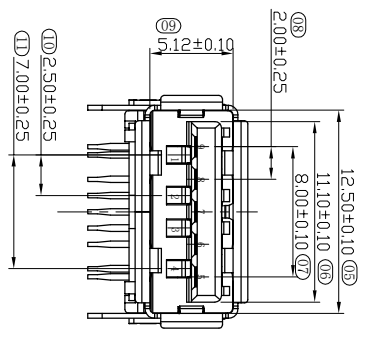
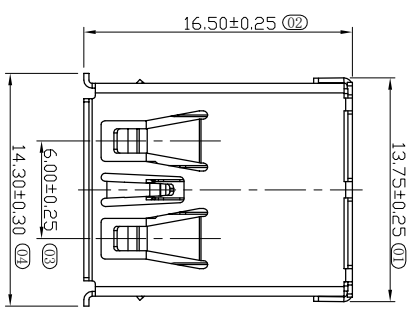

- SPECIFICATIONS:
- Electrical Performance:
 - Contact current Rating: 1.80 Amperes for VBUS and GND contacts, 0.25 Amperes for all other contacts
 - Dielectric Withstanding Voltage: AC 100V/minute
 - Insulation resistance: 100M ohms Min
 - Contact Resistance: 30m ohm Max for VBUS and GND contacts, 50m ohm Max for all other contacts
 - Voltage Rating : 30 Vac (rms)
 - Mechanical Performance:
 - Mating Force: 35N Max
 - Unmating Force: 10N Min; 8N Min After Durability.
 - Durability: 1500 cycles
 - Environmental Performance:
 - Temperature Range: 3.1.1 Operating Temperature: -25°C to +85°C, 3.2 Salt Spray 12h Min
 - MATERIAL:
 - Housing&Cover: LCP, Color: Blue UL94 V-0
 - Contact: 2.0 Contacts C5191, 3.0 Contacts C2680
 - Shell: C2680
 - PLATING:
 - Contact: Au Plated on contact area, Tin 100u" Plated on solder area
 - Shell: Nickel 50u" Plated underplating over all, 5.2 Shell: Nickel 30u" Min underplating over all.

产品图

深圳市鑫风雷电子有限公司

公差一览表 TOLERANCE UNLESS OTHERWISE SPECIFIED		单位 UNITS	MM	制图 DRAWING	王冠	产品料号 PRODUCT PART NO.	11005-U3AF001-X
X	±0.30	X'	±5°	审核 CHKD	雷永健	产品名称 PRODUCT NO.	USB 3.0 AF 90度DIP(引脚,脚长2.5)
.XX	±0.25	.X'	±2°	核准 APPD	雷永健	角法 VIEW	⊕ ⊖
.XXX	±0.15	.XXX'	±0.5°	日期 DATE		版本 VER	A0

此图由教育版产品制作 XIN FENG LEI ELECTRONIC CO.,LTD AND SHOULD NOT BE USED WITHOUT WRITTEN PERMISSION