

# RoHS Compliant

## 客户图

目録 MAPX	变更内容 MODIFICATION	日期 DATE
A0	NEW	09-10-20

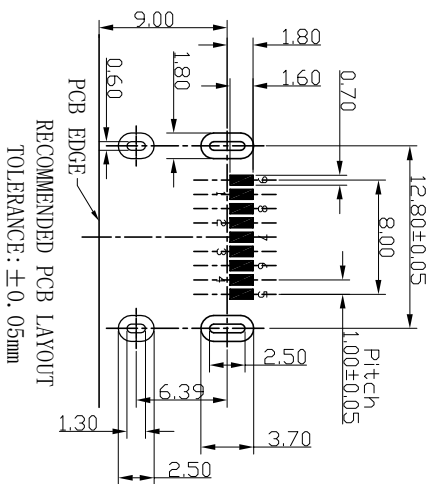
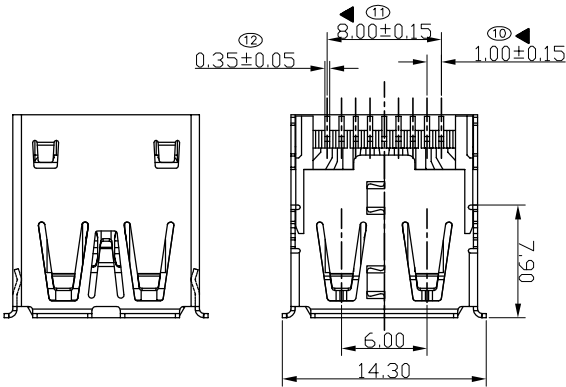
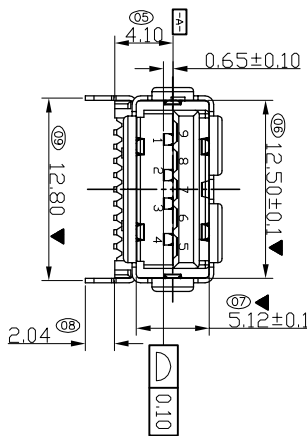
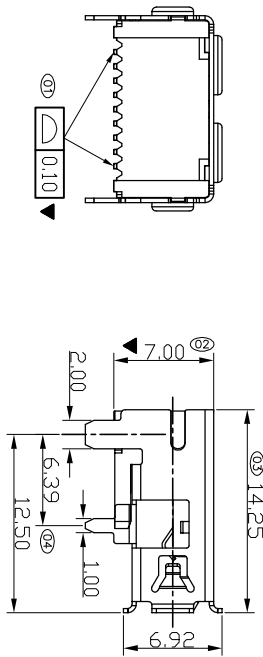

Pin NUMBER	SIGNAL NAME
1	VBUS
2	D-
3	D+
4	GND
5	Stda_SSRX-
6	Stda_SSRX+
7	GND_DRAIN
8	Stda_SSTX-
9	Stda_SSTX+
	Shell/shield

- NOTE:
- MATERIAL:
    - INSULATOR: HIGH TEMPERATURE PLASTIC
    - CONTACT: BRONZE,
    - SHELL: BRASS,
  - ELECTRICAL CHARACTERISTICS:
    - CONTACT RESISTANCE: 30mΩ MAXIMUM
    - CONTACT CURRENT RATING: 1.5A
    - DIELECTRIC WITHSTANDING VOLTAGE: 100 V AC R. M. S.
    - INSULATION RESISTANCE 100 MEGOHMS MIN
    - OPERATING TEMPERATURE: -40° C ~ 85° C
  - MECHANICAL CHARACTERISTICS:
    - MATING FORCE: 3.57kgf MAX
    - UNMATED FORCE: 0.82kgf MIN AFTER TEST
    - DURABILITY MANDATORY: 1,500 CYCLES
    - Salt Spray: 24 hours
  - PLATING
    - TERMINAL:
      - MIN NICKEL ALL OVER
      - MIN TIN ON SOLDER AREA (130)μ" Au ON CONTACT AREA
    - SHELL: 50μ" MIN. NICKEL ALL OVER

### 产品图

PRODUCT CHART DWG

### 深圳市鑫风雷电子有限公司

公差一览表		单位	MM	制图	王冠	产品料号	26015-U3AP011-A
TOLERANCE UNLESS OTHERWISE		UNITS		DRAWING		PRODUCT PART NO.	
X	±0.30	X'	±5'	审核	雷永健	产品名称	USB 3.0 A型板上SMT四脚前置
.XX	±0.25	.X'	±2'	核准	雷永健	脚间距	6.4 L=14.45有边
.XXX	±0.30	.XX'	±1'	日期		画法	
	±0.15	.XXX'	±0.5'	日期	2009/10/20	视图	
				核准	雷永健	版本	A0