

# RoHS 客户图

目錄 MAPX	變更內容 MODIFICATION	日期 DATE
A0	NEW	09-10-20

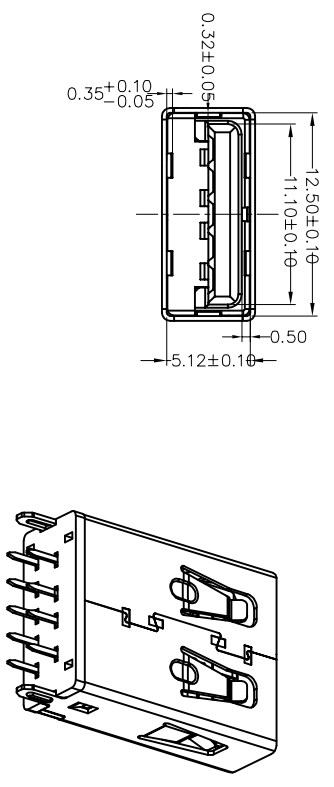

Specification:  
 1. Electrical Characteristics:  
 Contact Current Rating: 1.8 A  
 Dielectric Withstanding Voltage: AC 100V.  
 Insulation Resistance: 100 MΩ Min.  
 Contact Resistance:  
 30 mΩ (Max) initial for VBUS and GND contacts.  
 50 mΩ (Max) initial for all other contacts.  
 2. Mechanical Characteristics:  
 Insertion Force: 35N(3.57kgf) MAX  
 Extraction Force: 10N(1.02kgf) Min

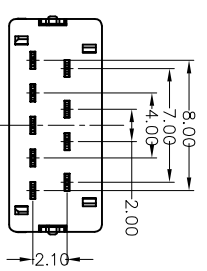
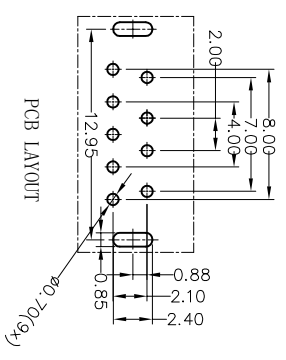
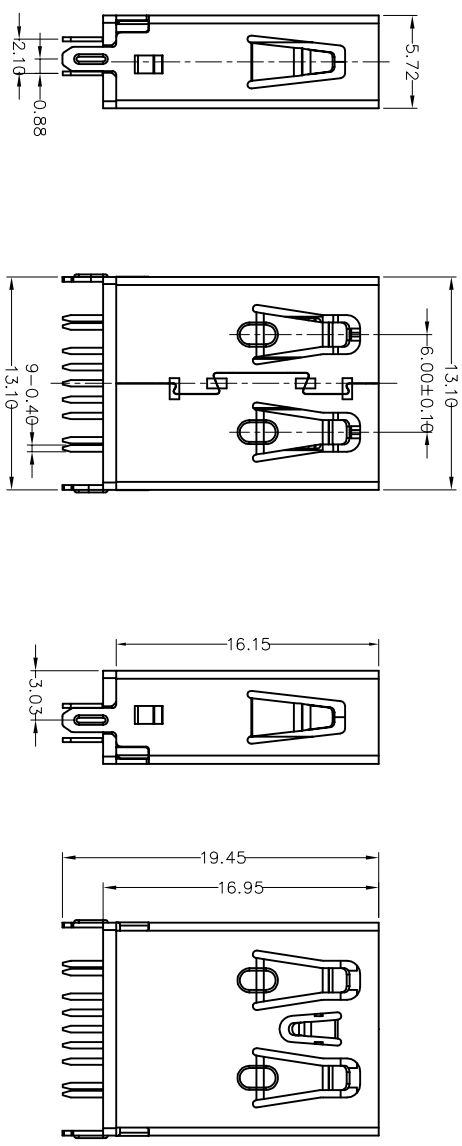

## 产品图

## 深圳市鑫风雷电子有限公司

公差一览表 TOLERANCE UNLESS OTHERWISE		单位 UNITS	制图 DRAWING	产品料号 PRODUCT PART NO.
X	±0.30	X'	王冠	19001-U3AF002-B
X	±0.25	X'	审核 雷永健	
XX	±0.30	XX'	核准 雷永健	
XXX	±0.15	XXX'		
比例 SCALE		日期 DATE	制图 DRAWING	产品名称 PRODUCT NO.
1:1		2009/10/20	王冠	USB3.0 AF 180度直脚无边H=17.0
角法 ANGLE		版本 VER		
		A0		