

1

2

3

4

5

6

7

8

9

10

11

12

13

14

15

16

17

18

19

20

21

22

23

24

25

26

27

28

29

30

31

32

ROHS 客户图

目錄 MAPX	變更內容 MODIFICATION	日期 DATE
A0	NEW	09-10-20

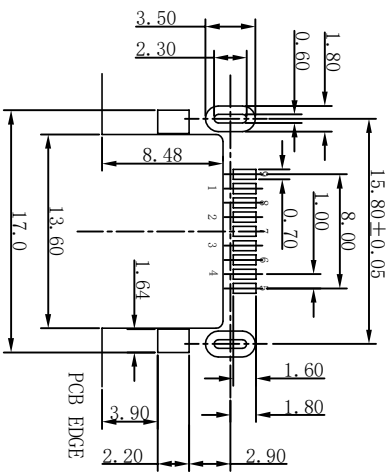
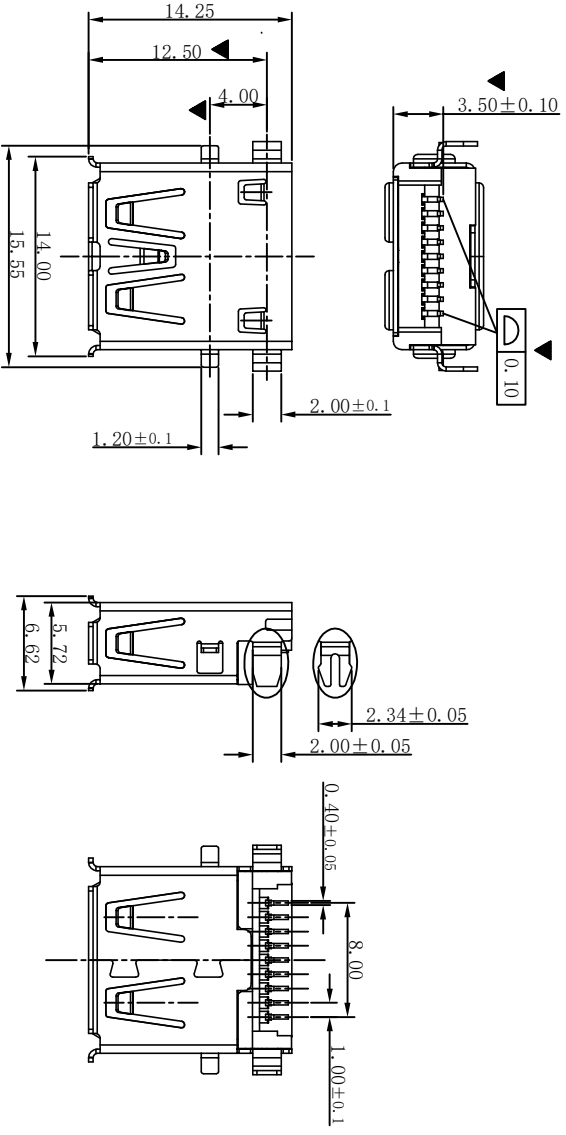

- NOTE:
- MATERIAL:
 - INSULATOR: LCP UL 94V-0
 - CONTACT: BRONZE (T=0.20mm)
 - SHELL: BRASS (T=0.30mm)
 - ELECTRICAL CHARACTERISTICS:
 - CONTACT RESISTANCE: 30mΩ MAXIMUM
 - CONTACT CURRENT RATING: 1.5A
 - DIELECTRIC WITHSTANDING VOLTAGE: 500 V R.M.S.
 - INSULATION RESISTANCE 1000 MEGOHMS MIN
 - OPERATING TEMPERATURE: -40° C ~ 85° C
 - MECHANICAL CHARACTERISTICS:
 - MATING FORCE: 3.57kg MAX
 - UNMATED FORCE: 1.02kg MIN
 - DURABILITY: MANDATORY: 5,000 CYCLES
 - PLATING
 - TERMINAL:
 - 50μ" MIN NICKEL ALL OVER
 - 100μ" MIN Tin ON SOLDER AREA (1~30) μ" Au ON CONTACT AREA
 - SHELL: 100μ" MIN. NICKEL ALL OVER
 - "▲" FOR MAJOR DIM

Pin NUMBER	SIGNAL NAME
1	VBUS
2	D-
3	D+
4	GND
5	StDA_SSRX-
6	StDA_SSRX+
7	GND_DRAIN
8	StDA_SSTX-
9	StDA_SSTX+
Shell	Shield

产品图

公差一览表 TOLERANCE UNLESS OTHERWISE SPECIFIED		单位 UNITS	MM
X	±0.30	X	±5°
X	±0.25	X	±2°
XX	±0.30	XX	±1°
XXX	±0.15	XXX	±0.5°

日期 DATE	2009/10/20	制图 DRAWING	王冠	产品料号 PRODUCT PART NO.	26015-13AP003-A
比例 SCALE	1:1	审核 CHECK	雷永健	产品名称 PRODUCT NO.	USB 3.0 AF 折板3.5 SMT有边方
日期 DATE	2009/10/20	核准 APPD	雷永健	脚利角叉脚 VIEW	版本 VER
					A0