

# ROHS 客户图

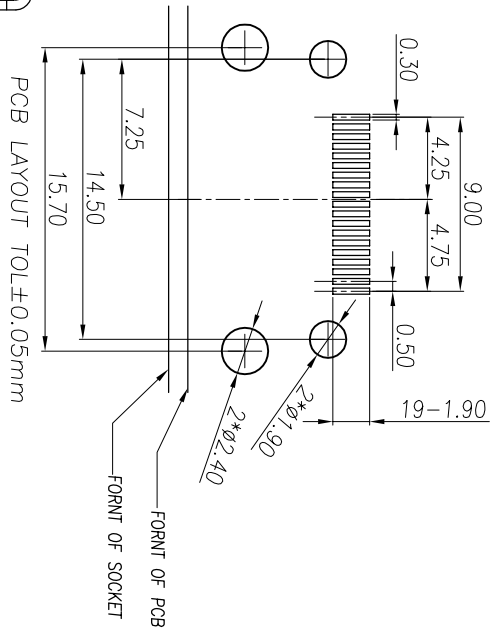
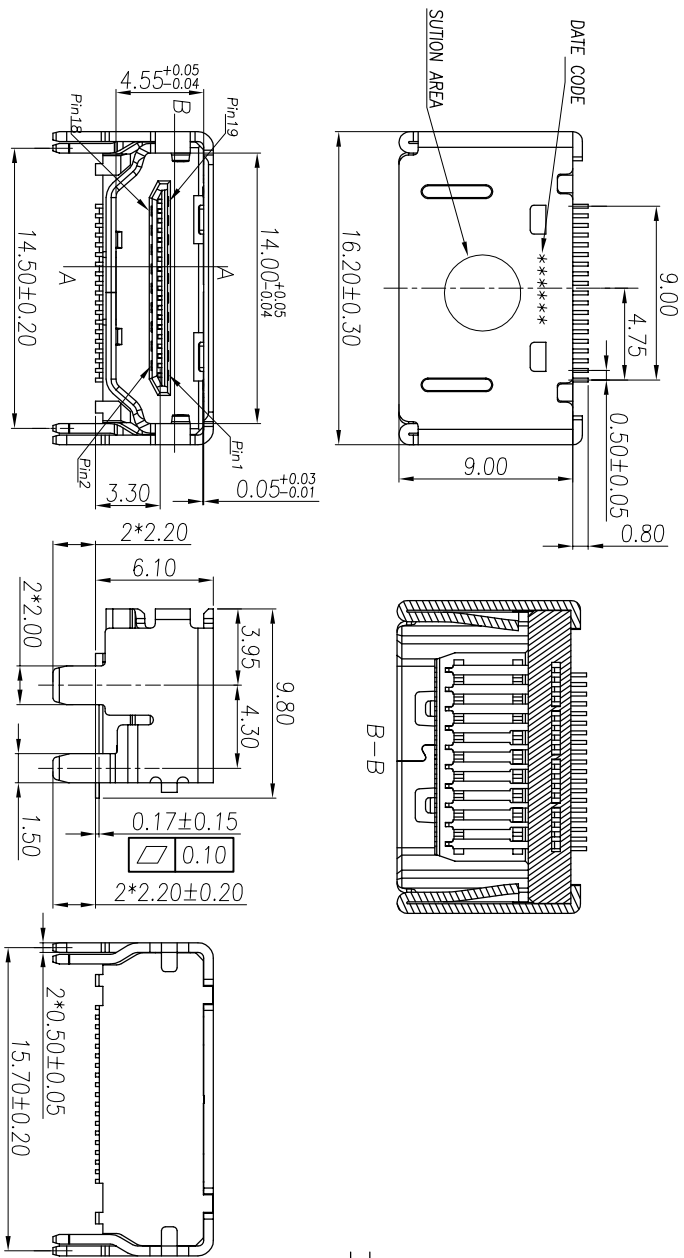

- NOTES:
- MATERIAL:
    - 1-1. HOUSING: LCP UL94 V-0, COLOR: BLACK;
    - 1-2. CONTACT: C2680 T=0.20±0.05mm;
    - 1-3. SHELL: SUS304, I=0.50±0.05mm;
  - PLATING:
    - 2-1. CONTACT: Au 3U" MIN. PLATING ON CONTACT AREA, SN 50U" MIN PLATING ON SOLDER TAILS, 50U" MIN. Ni UNDERPLATING OVERALL;
    - 2-2. SHELL: PLATING Ni 50U" MIN.
  - SPECIFICATIONS:
    - 3-1. VOLTAGE RATING: 40V
    - 3-2. CURRENT RATING: 0.5A
    - 3-3. INSULATION RESISTANCE: 100MΩ MIN. @500V DC
    - 3-4. CONTACT RESISTANCE: 30mΩ MAX
    - 3-5. DIELECTRIC WITHSTANDING VOLTAGE: 500V AC/1 MINUTE
    - 3-6. OPERATION TEMPERATURE: -20°C TO +85°C
    - 3-7. INSERT FORCE: 44 IN (4.5kgf) MAX.
    - 3-8. EXTRACT FORCE: 9.8~39.2N (1.0kgf~4.0kgf)
    - 3-9. LIFE: 10000 CYCLES MIN.

3	CONTACT	19	C2680R-H	PLATED Au/SN
2	SHELL	1	SUS304	PLATED Ni
1	HOUSING	1	LCP	UL94V-0 BkGk
NO.	ITEM	QTY	DESCRIPTION	FINISH

## 产品图

PRODUCT CHART DWG

深圳市鑫风雷电子有限公司  
Shenzhen xinfenglei Electronics Co., Ltd

公差一览表		单位		MM	
TOLERANCE UNLESS OTHERWISE		UNITS		MM	
X	±0.30	X	±5'	比例	
XX	±0.25	X'	±2'	SCALE	
XX	±0.20	XX'	±1'	日期	2009/10/20
XXX	±0.15	XXX'	±0.5'	日期	2009/10/20

制图	王冠	产品料号	26022-HDAF001-X
审核	雷永健	产品名称	HDMI A TYPE 19P母座上SN插座 E-9.0
核准	雷永健	PROUDCT NO.	
批准	雷永健	联系方式	mailbox: sale1@xfll.com, www. xfll.com, com