

# ROHS 客户图

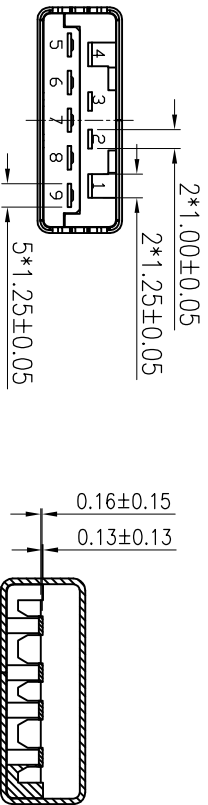

- NOTE:
- MECHANICAL :
    - INSERTION FORCE :35 N(3.57kgf) Max.
    - WITHDRAWAL FORCE :10 N(1.02kgf)
    - DURABILITY:5000cycles Extraction
  - ELECTRICAL :
    - CONTACT CURRENT RATING: 1.5A AT 250V AC. MIN.
    - WITHSTANDING VOLTAGE: 500 VAC FOR 1 MINUTE.
    - INSULATION RESISTANCE: 1000 MEGAOHMS MIN.
    - CONTACT RESISTANCE: 30 MILLIOHMS MAX.
  - ENVIRONMENTAL :
    - OPERATING TEMPERATURE:-25°C TO +85°C

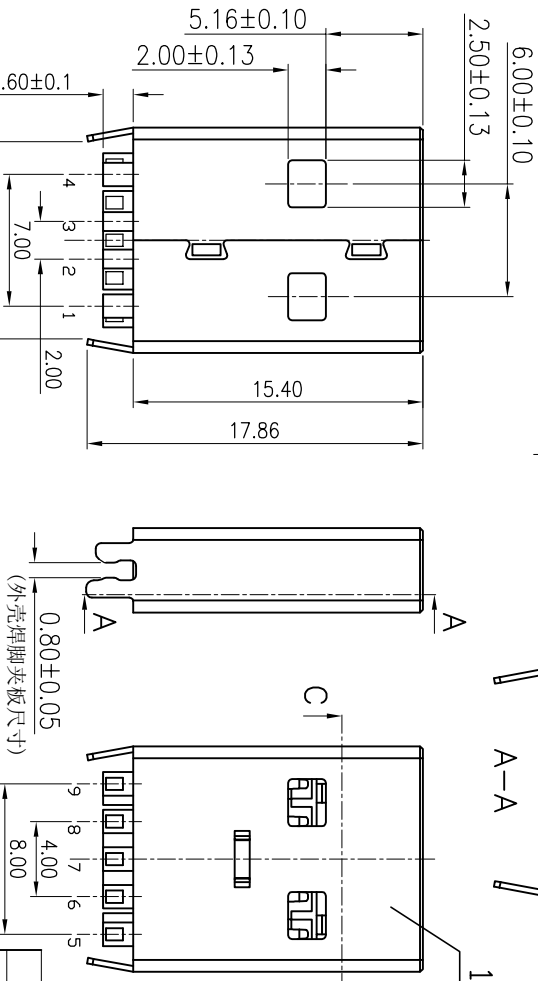
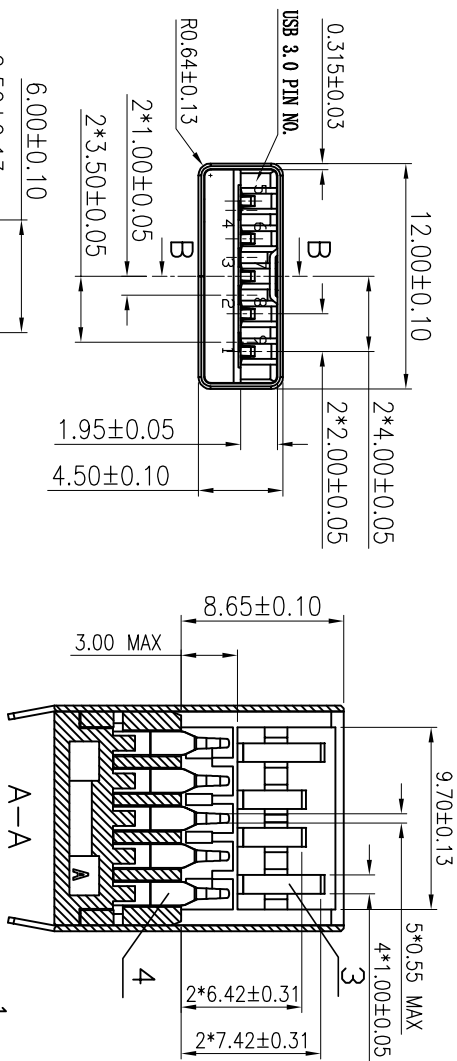
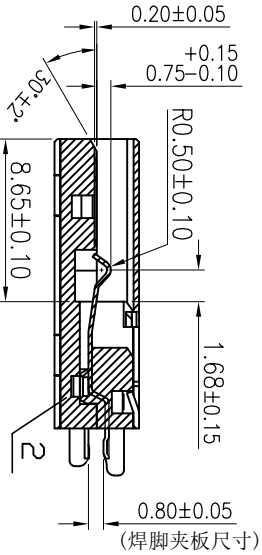

4	5P CONTACT	5	High performance copper alloy	SELECTED GOLD PLATED OVER
3	4P CONTACT	4	BRASS T=0.20mm	SELECTED GOLD PLATED OVER
2	INSULATOR	2	LCP, BLUE	ROHS U94-10
1	SHELL	1	SPCC T=0.30mm	NICKEL & GOLD PLATED
ITEM	PART NAME	QTY.	MATERIAL	REMARK

公差一览表 TOLERANCE UNLESS OTHERWISE SPECIFIED		单位 UNITS		比例 SCALE		日期 DATE	
X	±0.30	X'	±5'	1:1	2023/05/05		
XX	±0.25	XX'	±2'				
XXX	±0.15	XXX'	±0.5'				
PRODUCT CHART DWG 深圳市鑫风雷电子有限公司 Shenzhen xinfenglei Electronics Co., Ltd				制图 DRAWING 王冠 Wangguang 产品料号 PRODUCT PART NO. 17014-U3AM001-X			
审核 CHECK 雷永健 Lei Yongjian 产品名称 PRODUCT NO. USB3.0 A公短体一体式夹板0.8 L=15.4				核准 APPD 雷永健 Lei Yongjian 联系方式 CONTACT NO. mailbox: sale1@xfll.com www: xfll.com.com			

目錄 MAPX	變更內容 MODIFICATION	日期 DATE
A0	NEW	23-05-05