

# RoHS 客户图

目錄 MAPX	變更內容 MODIFICATION	日期 DATE
A0	NEW	23-05-05

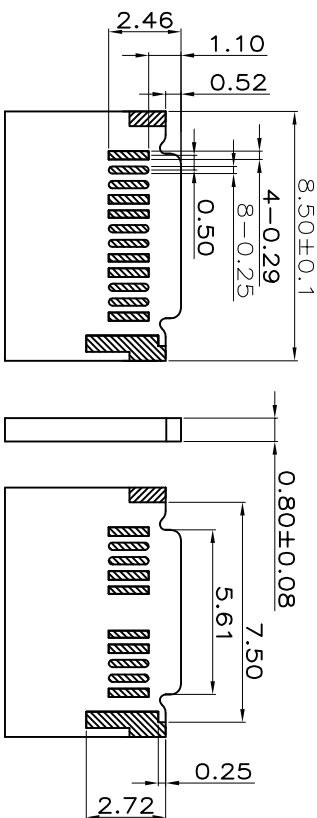
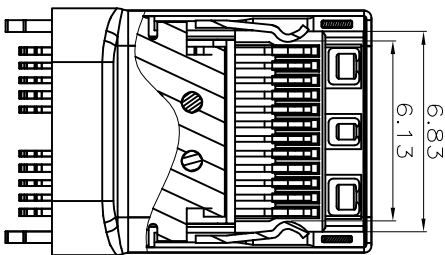
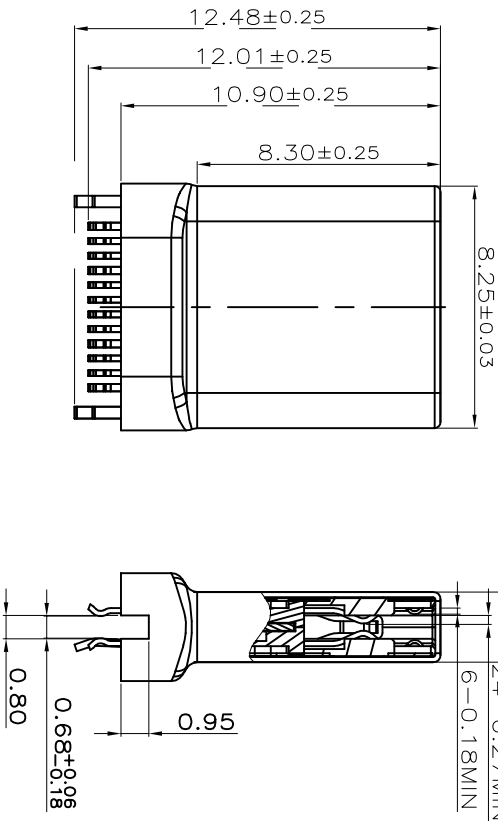
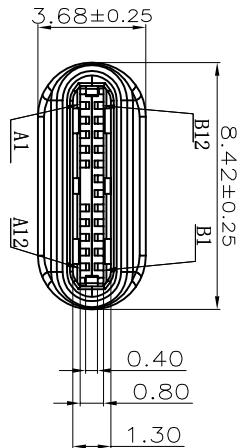

## PCB板制板参考图

- NOTES:
- MECHANICAL:
    - MATING FORCE: 5-20N.
    - UNMATING FORCE: 8-20N.
    - DURABILITY: 10000 CYCLES
  - ELECTRICAL:
    - CONTACT CURRENT RATING: 1.25A/PIN FOR VIBS AND GND, 0.9A/PIN FOR ALL OTHER CONTACT.
    - DIELECTRIC WITHSTANDING VOLTAGE: 100V AC AT SEA LEVEL.
    - LOW LEVEL CONTACT RESISTANCE: 40mΩ MAX FOR VIBS AND GND, 50mΩ MAX FOR OTHER CONTACTS.
    - INSULATION RESISTANCE: 100MΩ MIN AT 250VDC.
    - OPERATING TEMPERATURE: -55°~85°
  - Materials&Plating
    - Contact: High performance copper alloy C7025, 30u"Min Au ON CONTACT AREA,120u"Min TIN ON SOLDER AREA 60u"NICHEL UNDERPLATING OVERALL
    - Housing: LCP E1301 U194V-0
    - Shell: Stainless Steel SUS316L,60u" NICKEL PLATING OVER ALL.
    - Retention Latch:Stainless Steel SUS301,50u" NICKEL PLATING,100u"Min TIN ON SOLDER AREA
    - EMC Shielding Spring: Stainless Steel SUS304,1r:times

## 产品图

PRODUCT CHART DWG

### 公差一览表

TOLERANCE UNLESS OTHERWISE	公差	单位	比例	日期	制图	审核	核准	产品料号	产品名称	联系方式
UNITS	MM	UNITS	SCALE	DATE	DRAWING	CHKD	APPD	PRODUCT PART NO.	PRODUCT NO.	MAILBOX
X	±0.30	X'	±5'		王冠	雷永健	雷永健	17014-UCAM006-X	Type C 22pin拉伸公称厚度3.68夹板0.8不排板	mailbox: sale1@xfll.com
XX	±0.25	X''	±2'		雷永健	雷永健	雷永健			www.xfll.com
XXX	±0.20	XX'	±1'	2023/05/05	王冠	雷永健	雷永健			
	±0.15	XXX'	±0.5'		王冠	雷永健	雷永健			

深圳市鑫风雷电子有限公司  
Shenzhen xinfenglei Electronics Co., Ltd