

1 2 3 4 5 6 7 8 9 10

ROHS

客户图

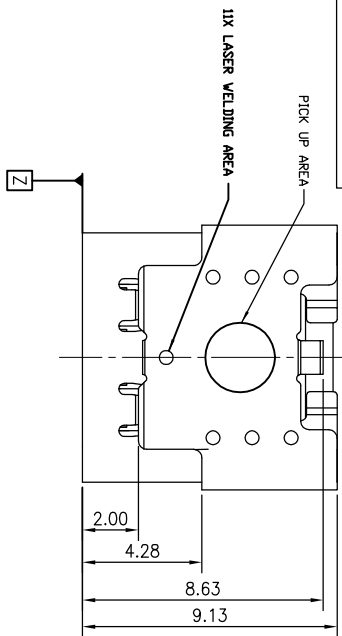

SECTION A-A

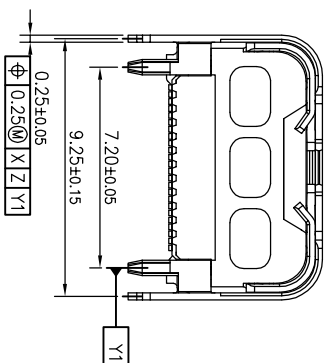
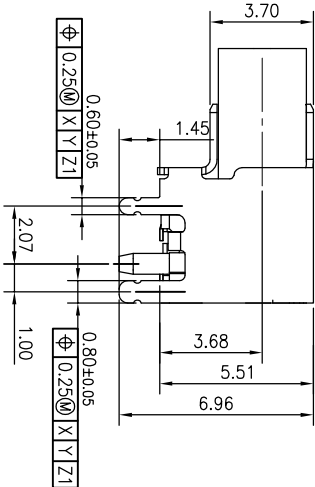
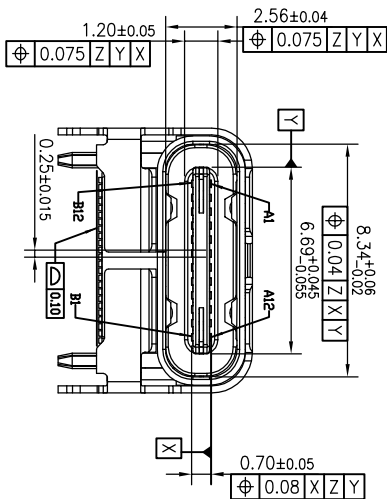
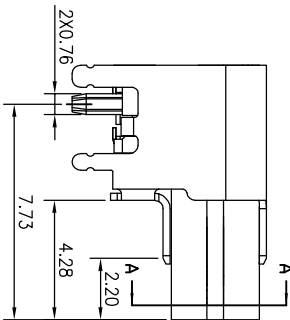
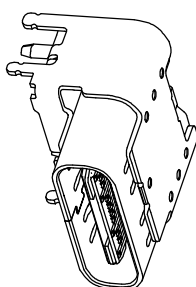
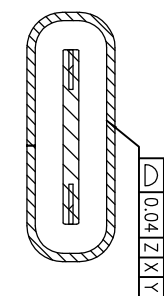

产品图

PRODUCT CHART DWG

公差一览表

| TOLERANCE UNLESS OTHERWISE SPECIFIED | 公差一览表 | 单位 | UNIT | 比例 | SCALE | 日期 | DATE | 制图 | DRAWING | 审核 | CHECK | 核准备案 | APPROVAL | 产品料号 | PRODUCT PART NO. | 产品名称 | PRODUCT NO. | 联系方式 | CONTACT INFO. |
|--------------------------------------|-------|-------|-------|-----|-------|------------|------------|----|----------|-----|--------------|------|--------------|-----------------|------------------|--------------|--|-------------------------|---------------|
| X | ±0.30 | X' | ±5' | 1:1 | 1:1 | 2009/10/20 | 2009/10/20 | 王冠 | Wangguan | 雷永健 | Lei Yongjian | 雷永健 | Lei Yongjian | 01013-UCAR013-X | 01013-UCAR013-X | 深圳市鑫风雷电子有限公司 | Shenzhen xinfenglei Electronics Co., Ltd | mailbox: sale1@xfll.com | www: xfll.com |
| X | ±0.25 | X' | ±2' | | | | | | | | | | | | | | | | |
| XX | ±0.20 | XX' | ±1' | | | | | | | | | | | | | | | | |
| .XXX | ±0.15 | .XXX' | ±0.5' | | | | | | | | | | | | | | | | |

RoHS 客户图

| | | |
|------------|----------------------|------------|
| 目錄 MAPX | 變更內容 MODIFICATION | 日期 DATE |
| A0 | NEW | 09-10-20 |

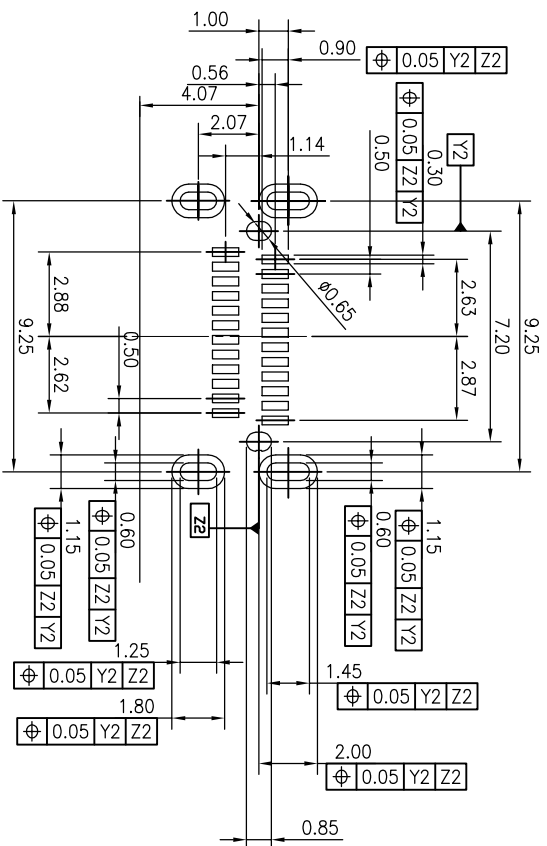

RECOMMEND PCB LAYOUT(TOP VIEW) SCALE:2:1
 (DATUM Z:PCB SOLDER SURFACE)
 (DEFAULT TOLERANCE:±0.05mm)

TABLE 2:CONNECTOR PIN ASSIGNMENTS

| PIN NUMBER | SIGNAL NAME | PIN NUMBER | SIGNAL NAME |
|------------|-------------|------------|-------------|
| A1 | GND | B12 | GND |
| A2 | SSTRXp1 | B11 | SSTRXp1 |
| A3 | SSTRXn1 | B10 | SSTRXn1 |
| A4 | VBUS | B9 | VBUS |
| A5 | CC1 | B8 | SBU2 |
| A6 | Dp1 | B7 | Dn2 |
| A7 | Dn1 | B6 | Dp2 |
| A8 | SBU1 | B5 | CC2 |
| A9 | VBUS | B4 | VBUS |
| A10 | SSTRXn2 | B3 | SSTRXn2 |
| A11 | SSTRXp2 | B2 | SSTRXp2 |
| A12 | GND | B1 | GND |

- NOTES:
- UNLESS OTHERWISE SPECIFIED AND/OR INDICATED, DIMENSIONS ARE TO FACE OF VIEW SHOWN AND AUTOMATICALLY ROUNDED BY COMPUTER FOR INSPECTION (SEE MATH MODEL FOR PRECISE DIMENSIONS), FOR ALL OTHER DIMENSIONS NOT SHOWN BUT REQUIRED FOR TOOL BUILD, SEE MATH MODEL FOR PRECISE TOOL PATH DATA/MATERIALS
 - ELECTRICAL SPECIFICATION:
 - 40milliorm MAX. FOR VBUS, GND AND OTHER CONTACTS
 - SOMMILION MAX. AFTER ENVIRONMENT TEST
 - CONTACT CURRENT RATING PARALLELED FOR A TOTAL OF 5A.
 - DIELECTRIC WITHSTANDING VOLTAGE: 100V AC (R.M.S).
 - INSULATION RESISTANCE 100 MEGOHM MIN.
 - MECHANICAL CHARACTERISTICS:
 - MATING FORCES-20N.
 - UNMATING FORCE:INITIAL 8-20N; 6-20N AFTER 10000 CYCLES
 - OPERATING TEMPERATURE:-55DEGREE- 85DEGREE
 - DURABILITY:1000 CYCLES
 - RECOMMENDED PROCESS CONDITION: SMT 260 DEGREE-5-10S.
 - PCB THICKNESS:1.6MM (REFERENCE).
 - TERMINAL PLATING SPECIFICATION:80u"MIN NI PLATING OVER ALL 300u"MIN Au PLATING ON THE CONTACT AREA, GOLD FLASH ON THE SOLDER AREA.

产品图

PRODUCT CHART DWG

公差一览表

| TOLERANCE UNLESS OTHERWISE | X | XX | XXX |
|----------------------------|-----|-------|-------|
| ±0.30 | X | ±0.20 | ±0.15 |
| ±0.25 | X | ±0.20 | ±0.15 |
| ±0.20 | XX | ±0.15 | ±0.10 |
| ±0.15 | XXX | ±0.10 | ±0.05 |

深圳市鑫风雷电子有限公司
 Shenzhen xinfenglei Electronics Co., Ltd

| 单位 UNITS | 制图 DRAWING | 审核 CHECK | 日期 DATE | 产品料号 PRODUCT PART NO. | 产品名称 PRODUCT NO. | 联系方式 CONTACT INFO |
|-------------|----------------|---------------------|------------|--------------------------|---------------------|--|
| MM | 王冠 Wangguan | 雷永健 Lei Yongjian | 2009/10/20 | 01013-UCAR013-X | 01013-UCAR013-X | mailbox: sale1@xfll.com www: xfll.com.com |

ROHS 客户图

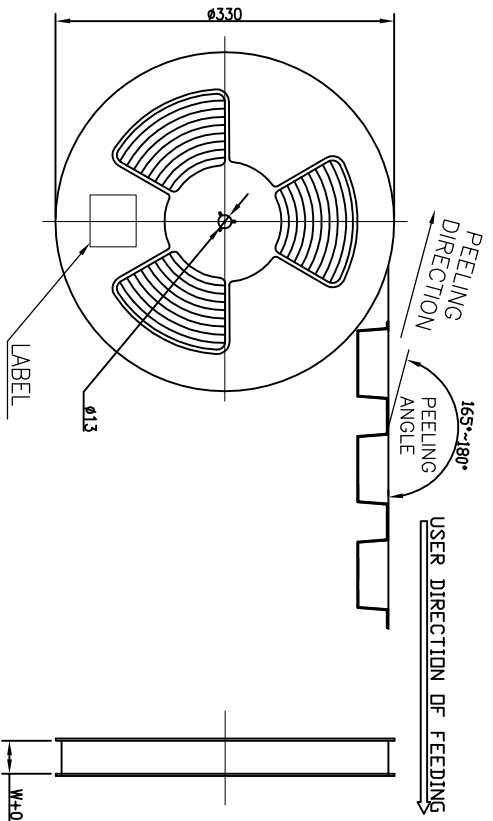
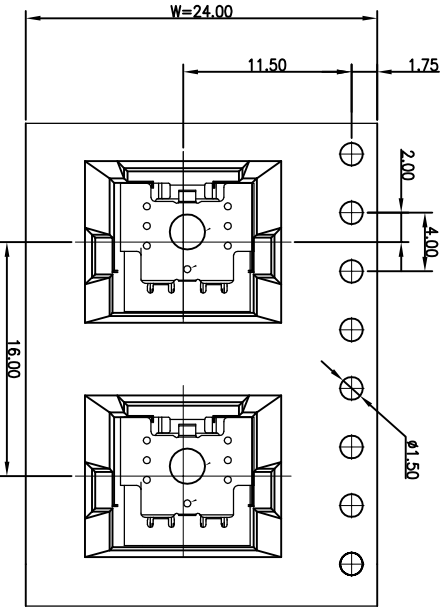
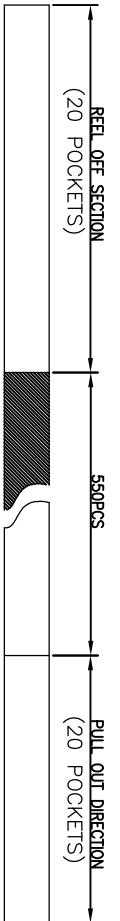

PRODUCT PACKAGING DIRECTION
CUSTOMER TO USE DIRECTION

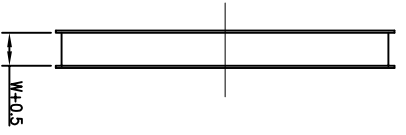

| | | |
|------------------|-----------------------------|------------------------|
| 目錄 MAPX A0 | 變更內容 MODIFICATION NEW | 日期 DATE 09-10-20 |
|------------------|-----------------------------|------------------------|

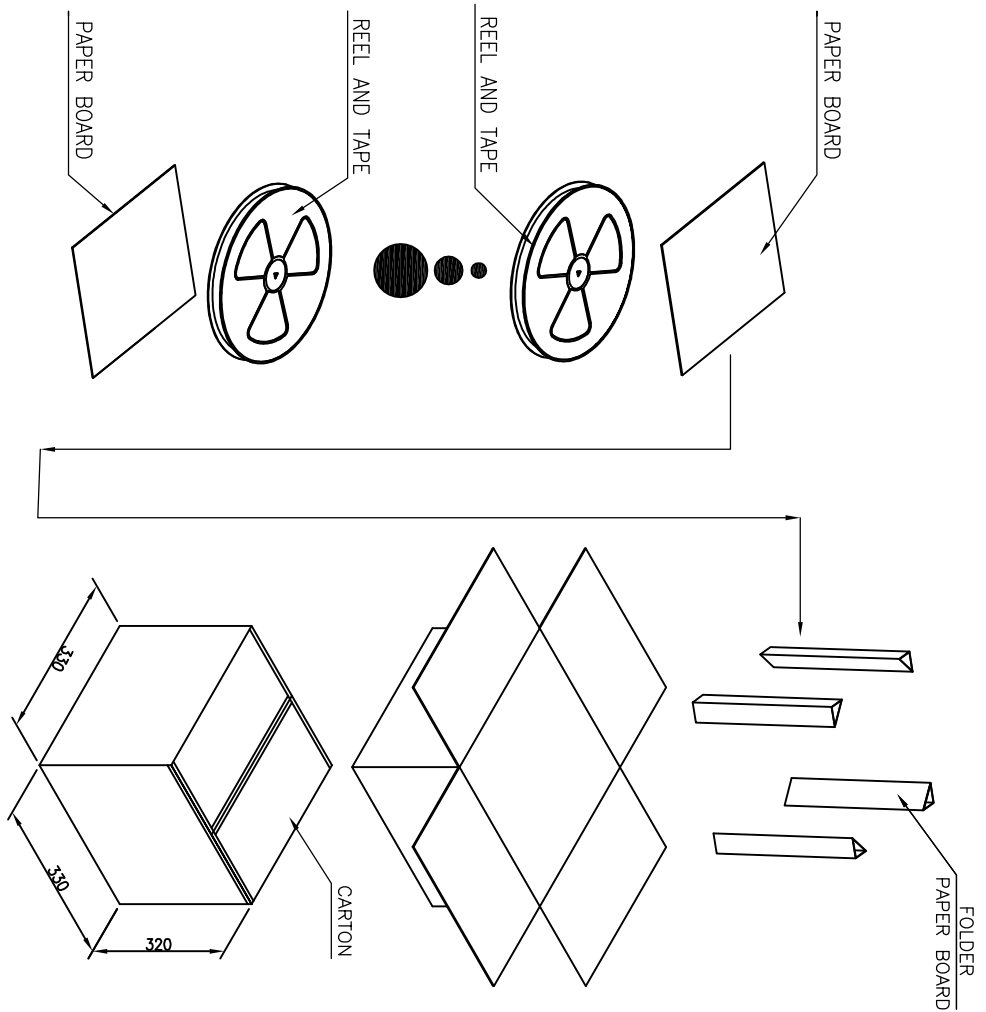

| | | | | | | | | | |
|----------------------------|-------|-----------------|-----|-----------------|--|------------------|--|--------------------------------------|--|
| 产品图 | | CONN. PART NO. | | CONN. QTY./REEL | | REEL QTY./CARTON | | CONN. QTY./CARTON | |
| 公差一览表 | | 01013-UCAF013-X | | 550 | | 10 | | 5500 PCS | |
| TOLERANCE UNLESS OTHERWISE | | CONN. PART NO. | | CONN. QTY./REEL | | REEL QTY./CARTON | | CONN. QTY./CARTON | |
| X | ±0.30 | X | ±5° | 王冠 | | 产品料号 | | 01013-UCAF013-X | |
| XX | ±0.25 | X' | ±2° | 雷永健 | | 产品名称 | | Type C 24V串接板上双轴加磁5.5 Ohm, 68 L=9.13 | |
| XXX | ±0.15 | XX' | ±1° | 雷永健 | | 联系方式 | | mailbox: sale1@xf.com, www: xf.com | |
| 日期 | | 日期 | | 审核 | | 审核 | | 审核 | |
| 2009/10/20 | | 2009/10/20 | | APPD | | APPD | | APPD | |

深圳市鑫风雷电子有限公司
Shenzhen xinfenglei Electronics Co., Ltd