

ROHS

客户图

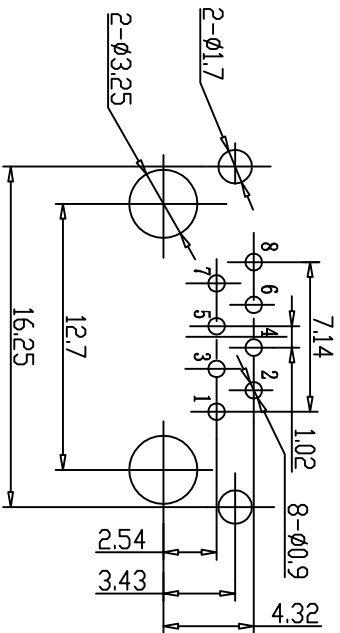

PC Board Layout

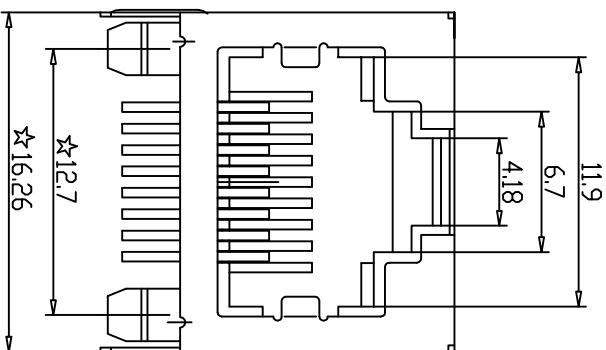
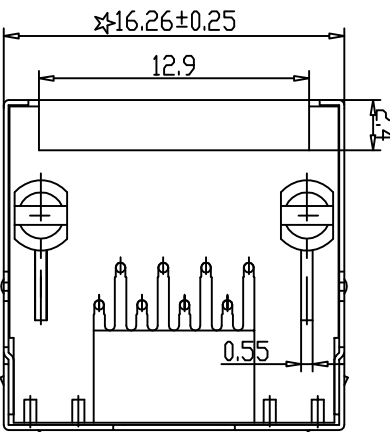
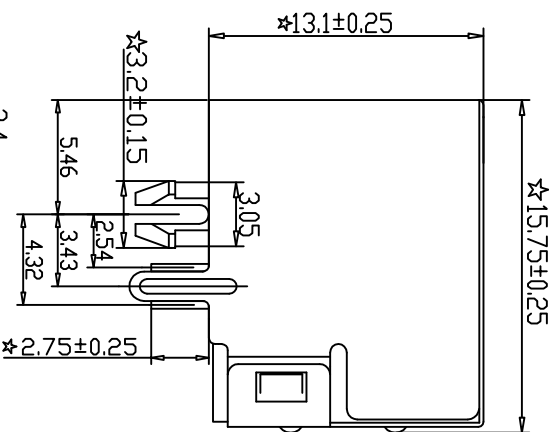

目錄 MAPX A0	變更內容 MODIFICATION NEW	日期 DATE 09-10-20
------------------	-----------------------------	------------------------

NOTES:

- ELECTRICAL:
- VOLTAGE RATING : 125 VAC RMS.
 - CURRENT RATING : 1.5 AMP.
 - CONTACT RESISTANCE : 30 MILLIOHMS MAX.
 - INSULATION RESISTANCE : 500 MEGOHMS MIN @ 500 VDC.
 - DIELECTRIC STRENGTH : 1000 VAC RMS 50Hz or 60Hz, 1MIN.

- MECHANICAL:
- HOUSING & INSERT MATERIAL : PBT UL94V-0.
 - CONTACT MATERIAL : DIAMETER 0.45MM PHOSPHOR BRONZE GOLD PLATING OVER NICKEL.
 - SHIELD : 0.20 ~ 0.25MM THICKNESS BRASS WITH NICKEL PLATED.
 - MATING/DUMMATING FORCE : 2.2KG.F MAX.
 - REPECTION STRENGTH : 7.7KG.F MIN BETWEEN JACK AND PLUG.
 - OPERATING LIFE : 600 CYCLES MIN.
- ENVIRONMENTAL:
- STORAGE : -10°C ~ +40°C RELATIVE HUMIDITY<70%.
 - OPERATION : -40°C ~ +70°C.

Remark:
1.Tolerances Unless Otherwise Specified
.0±0.25 .00±0.20 .000±0.10
2.The mark with ★ is the key inspection dimension for QC

产品图 PRODUCT CHART DWG		深圳市鑫风雷电子有限公司 Shenzhen xinfenglei Electronics Co., Ltd	
公差一览表 TOLERANCE UNLESS OTHERWISE		单位 UNITS MM	制图 DRAWING 王冠 Wangguan
X	±0.30	X	±5°
X	±0.25	X	±2°
XX	±0.20	XX	±1°
XXX	±0.15	XXX	±0.5°
日期 DATE	2009/10/20	比例 SCALE	1:1
审核 CHKD	雷永健 Lei Yongjian	产品料号 PRODUCT PART NO	17013-RJ45F01-X
核准 APPD	雷永健 Lei Yongjian	产品名称 PRODUCT NO	RJ45 90度 DTP 无灯无弹 (圆针)
		联系方式 Contact/Info	mailbox: sale1@xfll.com.com www_xfll.com.com