

# RoHS 客户图

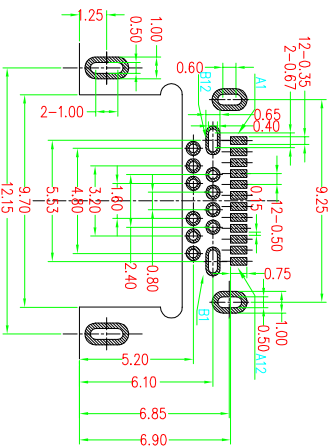

RECOMMEND PCB LAYOUT  
TOL=±0.05

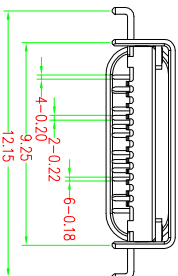
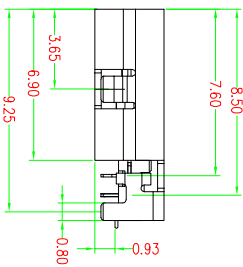
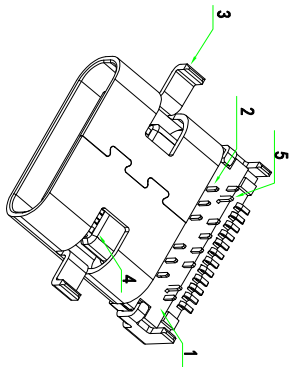
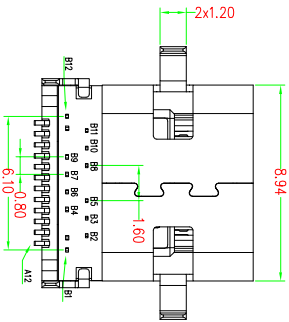
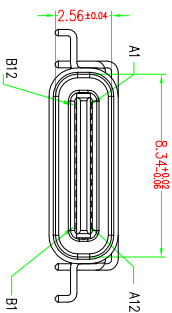
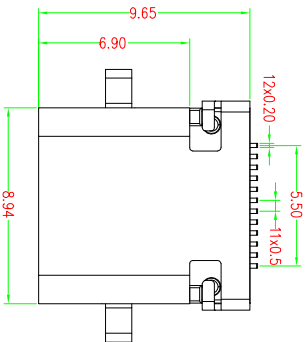
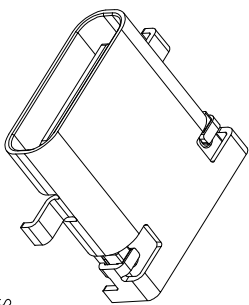

SPECIFICATION:

- 1:ELECTRICAL:
- 1-1:CURRENT RATING:  
VBUS AND GND CONTACTS RATED AT 1.25A  
PARALLELED FOR A TOTAL OF 5A;
- 1-2:INITIAL CONTACT RESISTANCE :40 MEGOHMS
- 1-3:DEELECTRIC WITHSTANDING VOLTAGE:  
100V AC MIN;
- 2:MECHANICAL CHARACTERISTICS:
- 2-1:MATING FORCE:5~20N
- 2-2:UNMATING FORCE:8~20N(INITIAL),  
6~20N(AFTER 10000 CYCLES)
- 2-3:FREQUENCY: 200±50 CYCLES /HOUR,10000 CYCLES
- 2-4:OPERATING TEMPERATURE ; -40~80°

TABLE B

AI1	GND	BI2	GND
A2	SSTRP1	BI1	SSTRP1
A3	SSTN1	BI0	SSTRN1
A4	VBUS	B9	VBUS
A5	CC1	B8	SBUS2
A6	DP1	B7	DN2
A7	DN1	B6	DP2
A8	SBUS1	B5	CC2
A9	VBUS	B4	VBUS
A10	SSTRN2	B3	SSTRN2
A11	SSTRP2	B2	SSTRP2
A12	GND	B1	GND
PN1	SIGNAL NAME	PN1	SIGNAL NAME

TABLE A

NO.	DESCRIPTION	MATERIAL	FINISH PLANTED	QTY	REMARKS
1	HOUSING	HIGH TEMPERATURE PLASTIC	BLACK	1PCS	
2	CONTACT	COPPER ALLOY	Au/Ni Plated	2SET	
3	SHELL	STAINLESS STEEL	---	1PCS	
4	GND-PLANT	STAINLESS STEEL	N/SN Plated	1PCS	
5	MI-PLANT	STAINLESS STEEL	---	1PCS	

## 深圳市鑫风雷电子有限公司

### 产品图

公差一览表 TOLERANCE UNLESS OTHERWISE SPECIFIED	单位 UNITS	MM	制图 DRAWING	王冠	产品料号 PRODUCT PART NO.	25001-UCAP002-X
X ±0.30	X'	±5°	审核 CHKD	雷永健	产品名称 PRODUCT NO.	TYPE C 24P母座深板1.0 前插后贴-9.65
XX ±0.25	X'	±2°	核准 APPD	雷永健	角法 VIEW	版本 VER
XXX ±0.15	XXX'	±0.5°	日期 DATE	2009/10/20		A0