

1 2 3 4 5 6 7 8 9 10

# ROHS

## 客户图

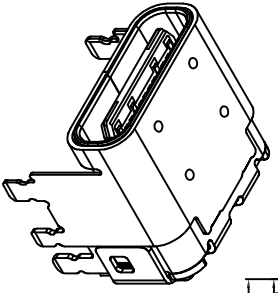
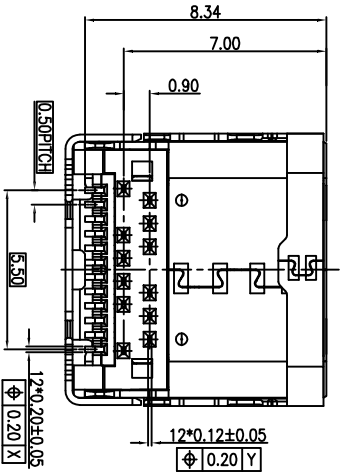
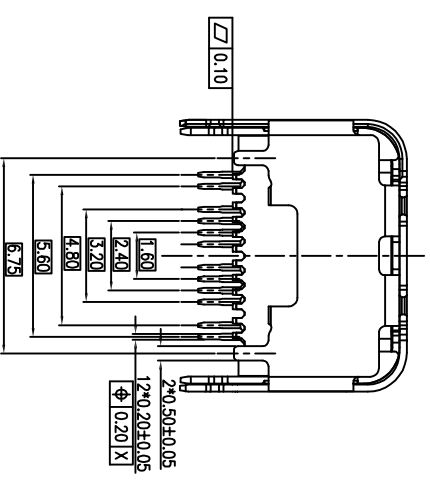
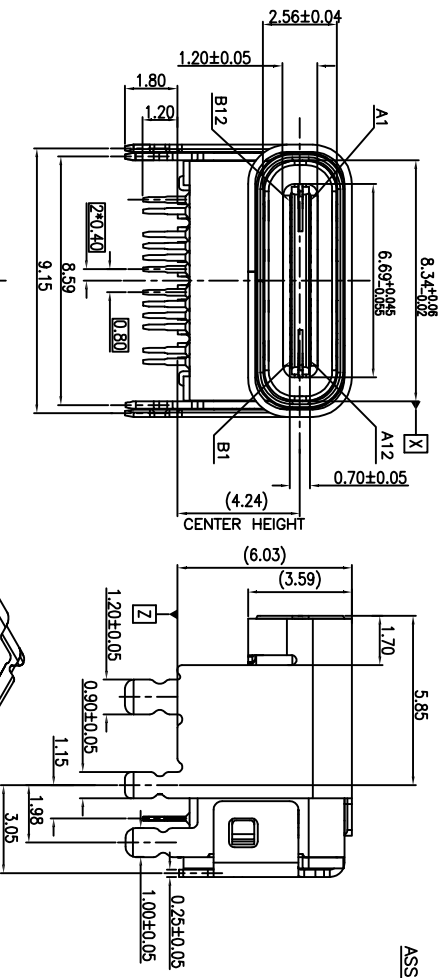
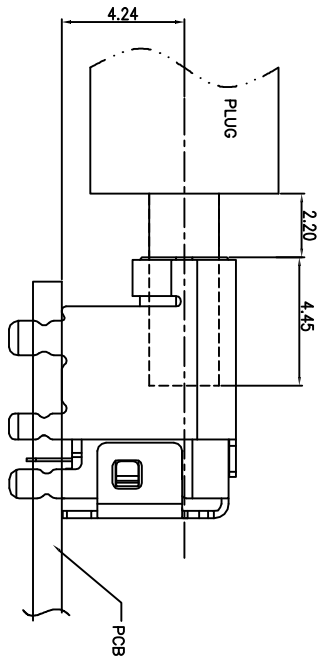
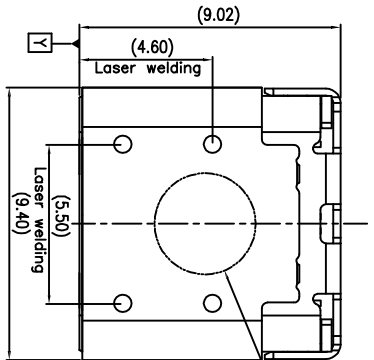

### 产品图

PRODUCT CHART DWG

### 公差一览表

TOLERANCE UNLESS OTHERWISE SPECIFIED	公差一览表
X	±0.30
X	±0.25
XX	±0.20
XXX	±0.15

### 深圳市鑫风雷电子有限公司

Shenzhen xinfenglei Electronics Co., Ltd

单位	制图	审核	产品料号	18003-UCAR005-X
MM	王冠	雷永健	产品名称	
1:1	雷永健	雷永健	联系方式	mailbox: sale1@xfll.com.com
比例	日期	日期	联系邮箱	www.xfll.com.com
SCALE	DATE	DATE	联系邮箱	
	2009/10/20	2009/10/20	联系邮箱	
			联系邮箱	

目録	变更内容	日期
MAPX	MODIFICATION	DATE
A0	NEW	09-10-20

# RoHS 客户图

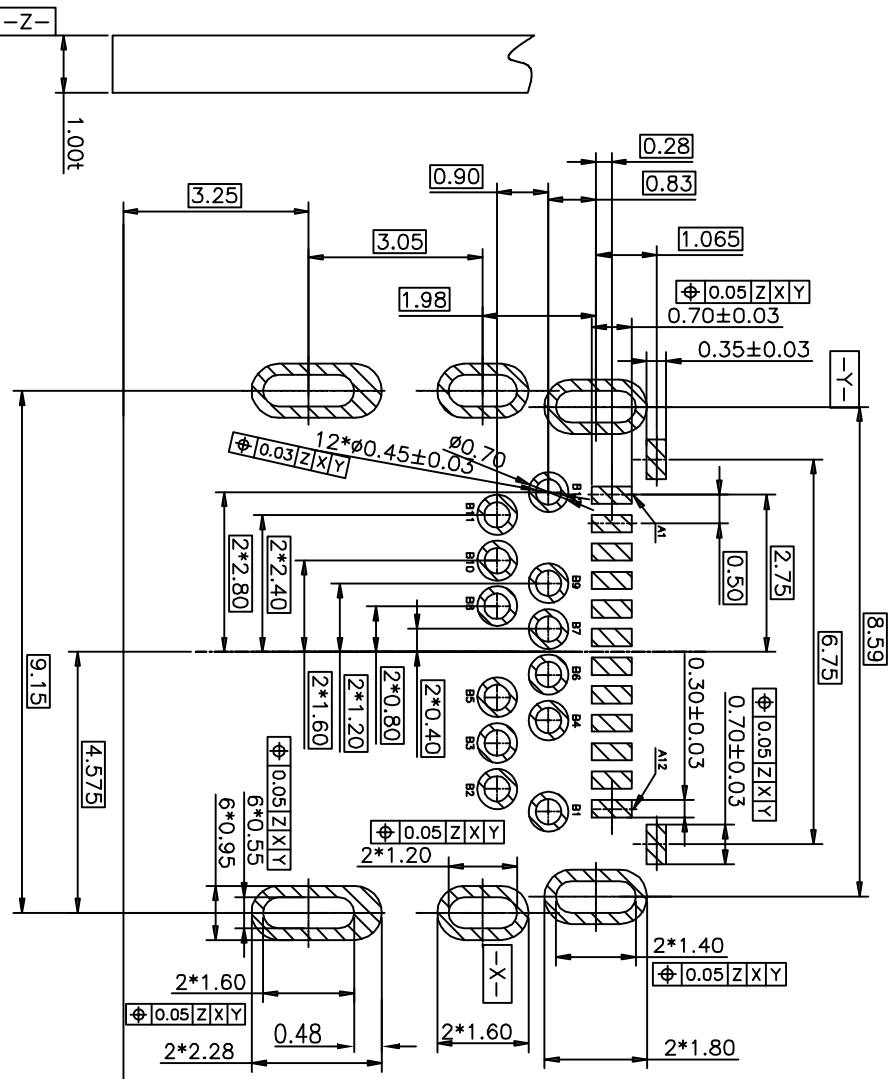

RECOMMENDED PCB LAYOUT T=1.00mm (TOP VIEW)  
SCALE: 2:1 TOL.:±0.05

INTERFACE(FRONT VIEW)											
A1	A2	A3	A4	A5	A6	A7	A8	A9	A10	A11	A12
GND	SSTRxp1	SSTRXn1	Vbus	CC1	Dp1	Dn1	SBU1	Vbus	SSTRXn2	SSTRx2	GND
GND	SSRxp1	SSSRXn1	Vbus	SBU2	Dn2	Dp2	CC2	Vbus	SSTRXn2	SSTRx2	GND
B12	B11	B10	B9	B8	B7	B6	B5	B4	B3	B2	B1

## 产品图

PRODUCT CHART DWG

### 公差一览表

TOLERANCE UNLESS OTHERWISE SPECIFIED	公差
X	±0.30
XX	±0.25
XXX	±0.15
X	±0.50
XX	±0.20
XXX	±0.15
X	±2
XX	±1
XXX	±0.5

## 深圳市鑫风雷电子有限公司

Shenzhen xinfenglei Electronics Co., Ltd

单位	MM	制图	王冠	产品料号	18003-UCAP005-X
比例	1:1	审核	雷永健	产品名称	
日期	2009/10/20	核准	雷永健	联系方式	mailbox: sale@xf.com www: xf.com.com

ITEM	PART NAME	QTY	MATERIAL	REMARK
①	TOP SHELL	1 PCS	STAINLESS STEEL	500* MIN. MIN. SOLDERABLE IN PLATING ON SOLDER AREA.
②	INNER SHELL	1 PCS	STAINLESS STEEL	500* MIN. NI PLATING ON SOLDER AREA.
③	HOUSING	1 PCS	LOP-U94W-0	BLACK
④	MID PLATE	1 PCS	STAINLESS STEEL	NO PLATING
⑤	BOTTOM CONTACT	1 SET	COPPER-ALLOY	80U* MIN. WHITE TIN PLATING ON SOLDER AREA.
⑥	TOP CONTACT	1 SET	COPPER-ALLOY	GOLD PLATING ON CONTACT AREA(SEE PART NUM)

- NOTES:
- ELECTRICAL CHARACTERISTICS:
    - CONTACT CURRENT RATING: 5.0 A FOR VBUS PIN AND ITS CORRESPONDING GND PIN. 0.25 A MIN FOR ALL OTHER CONTACTS.
    - CONTACT RESISTANCE: INITIAL 40 mΩ Max. AFTER 50 mΩ Max.
  - MECHANICAL CHARACTERISTICS:
    - 1-3. DIELECTRIC WITHSTANDING VOLTAGE: 100 VRMS AC MIN.
    - 1-4. INSULATION RESISTANCE: 100 MEGOHMS MIN.
    - 2-1. CONNECTOR INSERTION FORCE: 5~20N. AT A MAXIMUM RATE OF 125MM PER SECOND.
    - 2-2. CONNECTOR EXTRACTION FORCE: 8~20N FORM 1000 CYCLES 6~20N FORM 1000 to 10000 CYCLES
    - 2-3. DURABILITY: 10000 CYCLES.
    - 2-4. OPERATING TEMPERATURE: -55°C TO +85°C DIMENSIONS ARE IN MILLIMETERS, BRACKETED DIMENSIONS ARE INCHES EQUIVALENTS.
  - RECOMMENDED PROCESS: IR REFLOW 260°C, 10 SECONDS.
  - THE CONNECTOR IS ROHS COMPLIANT.

目錄	修改內容	日期
MAPX	MODIFICATION	DATE
A0	NEW	09-10-20

ROHS

客户图

目録 MAPX	变更内容 MODIFICATION	日期 DATE
A0	NEW	09-10-20

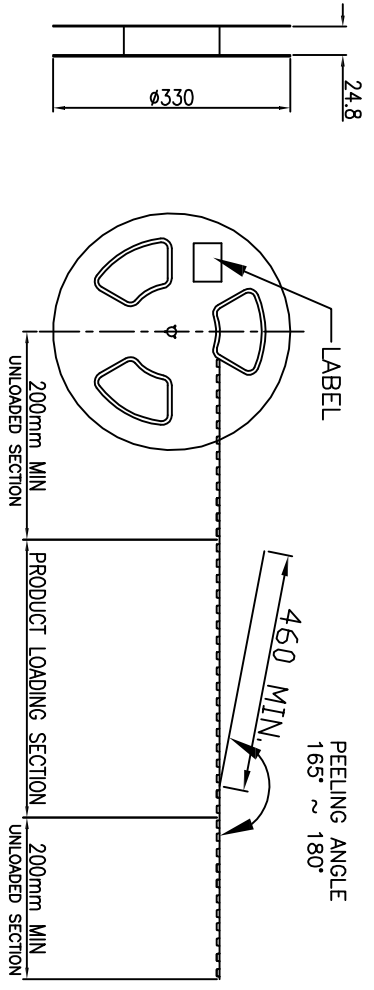

- NOTES :
1. MATERIAL :  
COVER TAPE : P.S T=0.05mm  
CARRIER TAPE : P.S T=0.50mm  
CARTON: CORRUGATED FIBER
  2. DIMENSION :
  3. QUANTITY : SEE DRAWING  
REEL : SEE DRAWING  
SHIPPING BOX: 350X350X300mm
  4. PEELING RESISTANCE : 10gf~130gf (for 12~56mm)
  5. PEELING SPEED : 300mm/MINUTES

PULL OUT DIRECTION

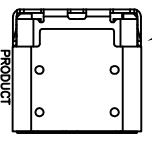
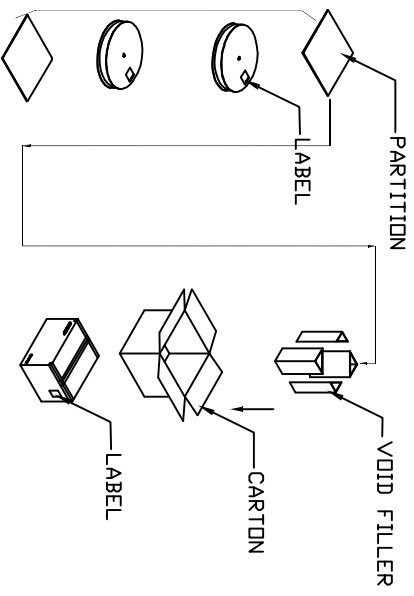
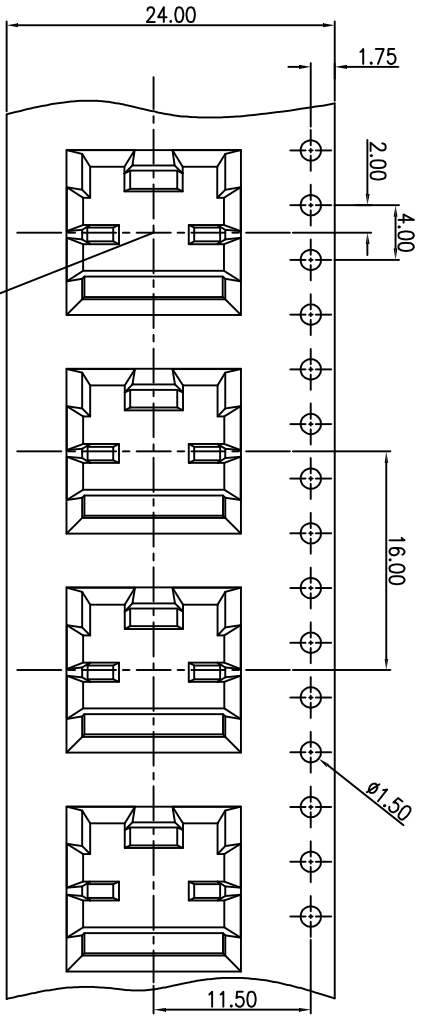

450	9	4050
PCS/REEL	REEL/BOX	TOTAL Q'TY

产品图

公差一览表

PRODUCT CHART DWG	深圳市鑫风雷电子有限公司 Shenzhen xinfenglei Electronics Co., Ltd		
TOLERANCE UNLESS OTHERWISE	单位 UNITS	制图 DRAWING	产品料号 PRODUCT PART NO.
X ±0.30	MM	王冠 Wangguan	18003-UCAR005-X
X ±0.25	1:1	审核 CHKD	产品名称 PRODUCT NO.
XX ±0.20	比例 SCALE	雷永健 Lei Yongjian	联系方式 CONTACT NO.
XXX ±0.15	日期 DATE	核准 APPD	雷永健 Lei Yongjian
			联系邮箱 Mailbox: sale1@xfl.com.com
			www.xfl.com.com