

# RoHS 客户图

目錄 MAPX	變更內容 MODIFICATION	日期 DATE
A0	NEW	09-10-20

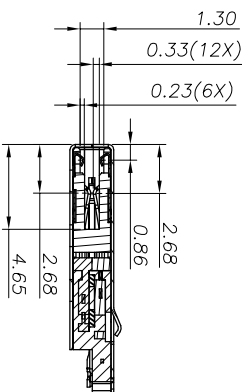
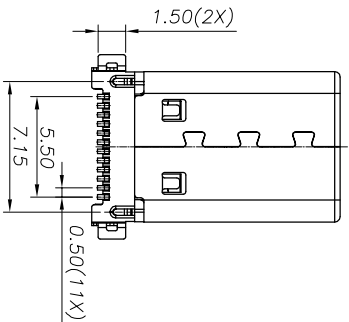
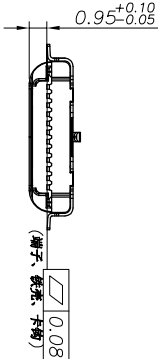
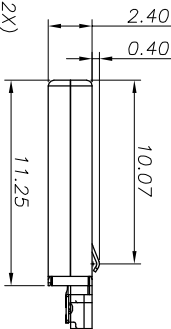
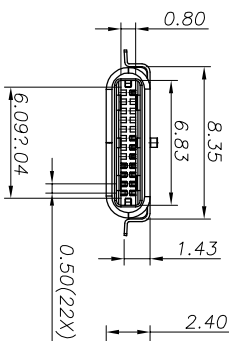
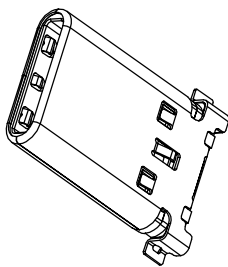
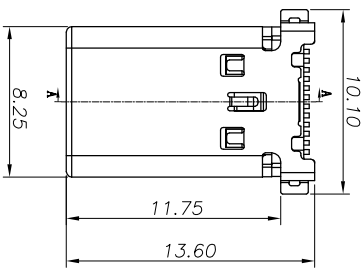

SECTION A-A  
SCALE: 1:1

- NOTE:
- MATERIAL SPECIFICATION:
    - HOUSING: HIGH TEMPERATURE RESISTANT PLASTIC, UL94 V-0.
    - CONTACTS: COPPER ALLOY
    - MID PLATE: STAINLESS STEEL
    - FRONT SHELL: STAINLESS STEEL
    - EMI PLATE: STAINLESS STEEL
  - PLATING SPECIFICATION:
    - CONTACTS:
      - Ni 50u" MIN. UNDER PLATED OVER ALL.
      - AU PLATED ON THE FUNCTIONAL AREA OF CONTACT.
    - FRONT SHELL:
      - (GOLD PLATING THICKNESS FOLLOW THE P/N)
      - PLATING SPECIFICATIONS OF THE SOLDER AREA FOLLOW THE P/N
    - MID PLATE & EMI PLATE:
      - PLATING SPECIFICATIONS FOLLOW THE P/N
      - CLEAR ONLY
  - MECHANICAL PERFORMANCE:
    - INSERTION FORCE: 0.5~2.0kgf.
    - REMOVAL FORCE: 0.8kgf~2.0kgf.
    - DURABILITY: 10000 CYCLES.
  - ELECTRICAL PERFORMANCE:
    - CURRENT RATING: 5.0A
    - VOLTAGE RATING: 5.0V
  - LCR:
    - VBUS & GND PINS AND OTHER PINS: 40mΩ/PIN MAX.
    - SHIELD: 50mΩ/MAX.
    - LCR MAX. CHANGE OF ALL PINS: 10mΩ.
  - INSULATION RESISTANCE: 100MΩ MIN
  - DIELECTRIC WITHSTAND VOLTAGE: AC 100V FOR 1 MINUTE.
  - ENVIRONMENTAL PERFORMANCE:
    - OPERATING TEMPERATURE: -25~+85℃.
    - IR REFLOW:
      - THE PEAK TEMPERATURE ON THE BOARD SHALL BE MAINTAINED FOR 10 SECONDS AT 260°C.

## 产品图

PRODUCT CHART DWG

### 公差一览表

TOLERANCE UNLESS OTHERWISE	UNIT
X	±0.30
X	±0.25
XX	±0.30
XXX	±0.15

## 深圳市鑫风雷电子有限公司

单位 UNITS	MM	制图 DRAWING	王冠	产品料号 PRODUCT PART NO.	24001-UCAM003-X
比例 SCALE	1:1	审核 CHKD	雷永健	产品名称 PRODUCT NO.	TYPE C 12P 公头单排SMT
日期 DATE	2009/10/20	核准 APRD	雷永健	角法 VIEW	版本 VER
					A0

# RoHS 客户图

目錄 MAPX	变更内容 MODIFICATION	日期 DATE
A0	NEW	09-10-20

## USB TYPE-C PIN ASSIGNMENTS

PIN NUMBER	SIGNAL NAME	PIN NUMBER	SIGNAL NAME
A1	GND	B12	GND
A2	SSTXp1	B11	SSRXp1
A3	SSTXn1	B10	SSRXn1
A4	VBUS	B9	VBUS
A5	CC1	B8	
A6	Dp1	B7	
A7	Dn1	B6	
A8		B5	
A9		B4	
A10		B3	
A11		B2	
A12	GND	B1	

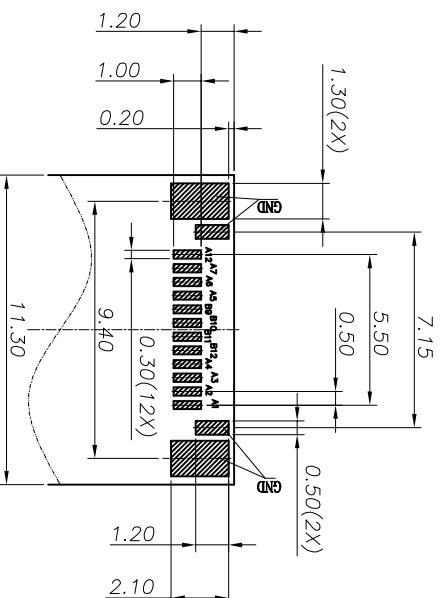

RECOMMENDED PCB LAYOUT(TOP VIEW)  
TOLERANCE:±.2.05

## 产品图

## 深圳市鑫风雷电子有限公司

公差一览表 TOLERANCE UNLESS OTHERWISE SPECIFIED		单位 UNITS	MM	制图 DRAWING	王冠	产品料号 PRODUCT PART NO.	24001-UCAM003-X
X	±0.30	X'	±5'	比例 SCALE	1:1	审核 CHKD	雷永健
X	±0.25	X'	±2'	日期 DATE	2009/10/20	核准 APPD	雷永健
.XX	±0.30	.XX'	±1'	角法 VIEW	⊕	版本 VER	A0
.XXX	±0.15	.XXX'	±0.5'				

# RoHS 客户图

目錄 MAPX A0	變更內容 MODIFICATION NEW	日期 DATE 09-10-20
------------------	-----------------------------	------------------------

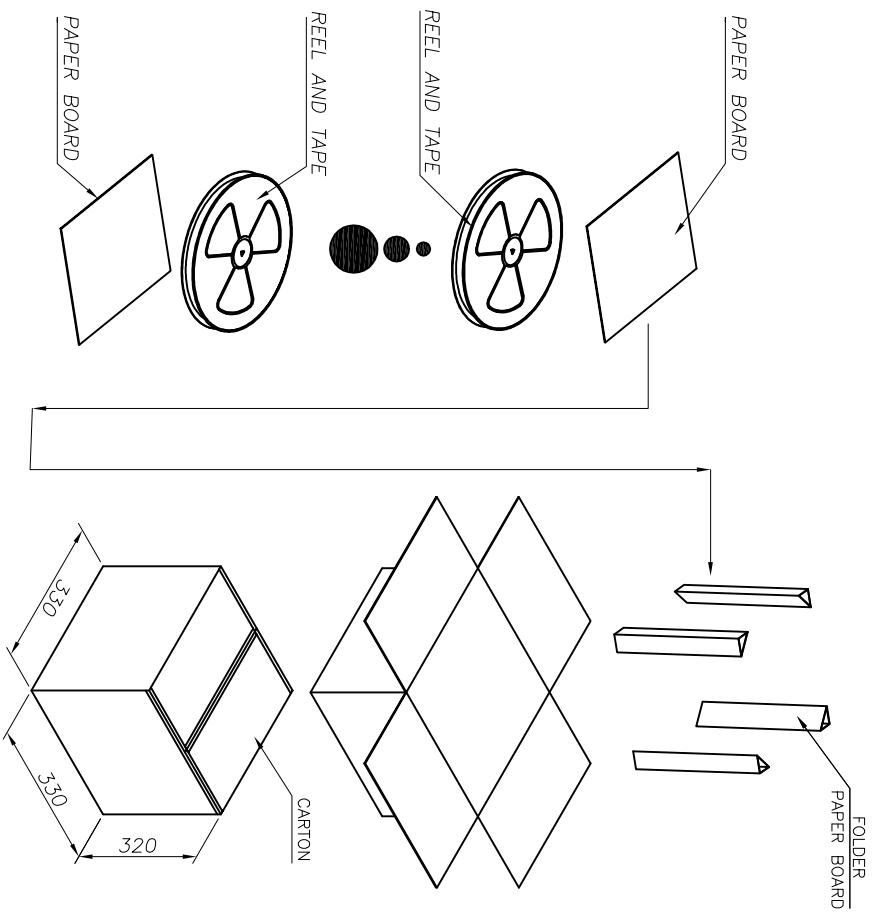
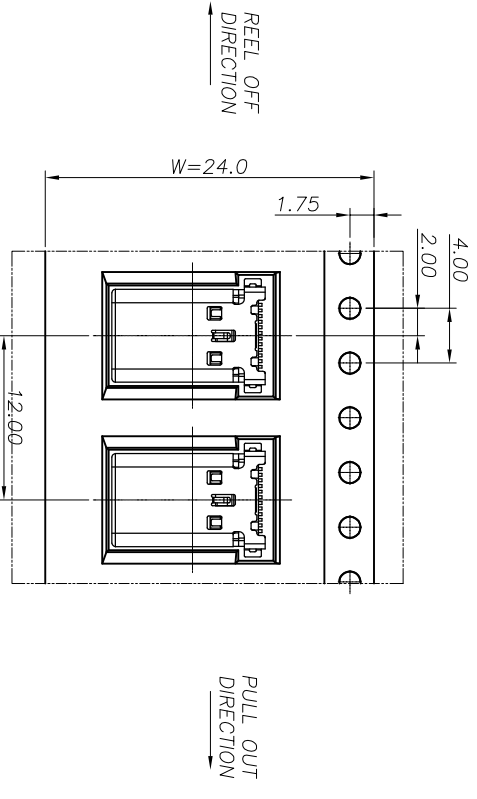
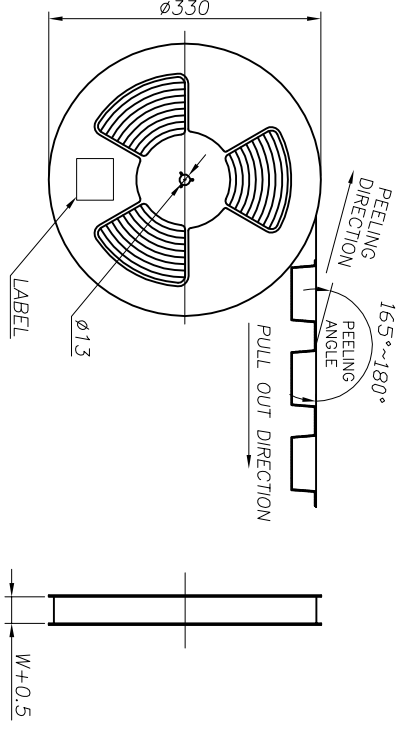
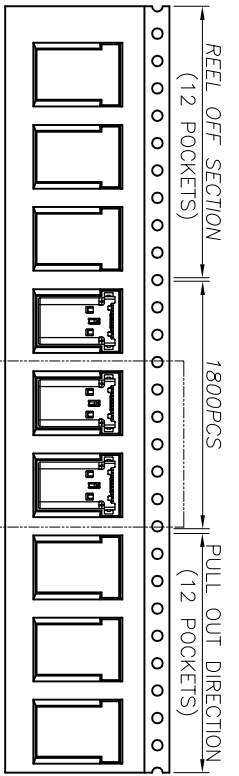

CONNECTOR (PCS)	REEL	CARTON
	1800	18000

## 产品图

公差一览表 TOLERANCE UNLESS OTHERWISE		单位 UNITS	MM	制图 DRAWING	王冠	产品料号 PRODUCT PART NO.	24001-UCAM003-X
X	±0.30	X'	±5'	审核 CHKD	雷永健	产品名称 PRODUCT NO.	TYPE C 12P公头单排SMT
.XX	±0.25	.XX'	±2'	核准 APPD	雷永健	角法 VIEW	
.XXX	±0.30	.XXX'	±1'	日期 DATE		版本 VER	A0
	±0.15	.XXX'	±0.5'				