

ROHS 客户图

目錄 MAPX 40	變更內容 MODIFICATION NEW	日期 DATE 09-10-20
------------------	-----------------------------	------------------------

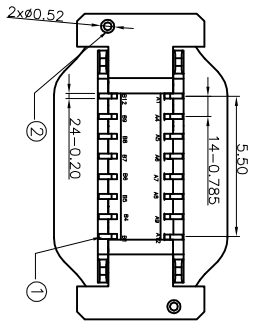
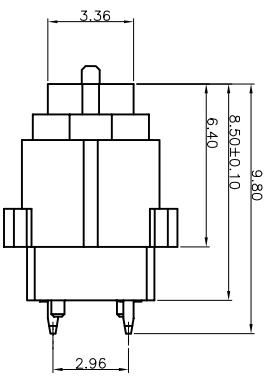
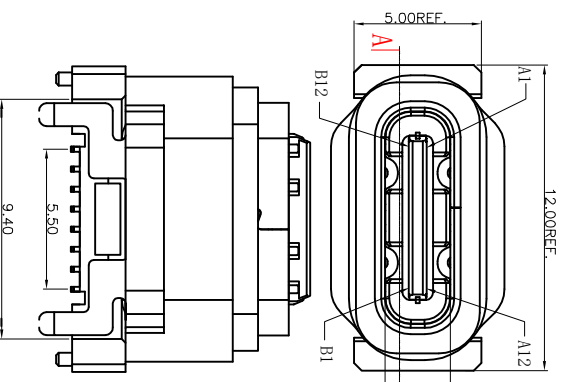
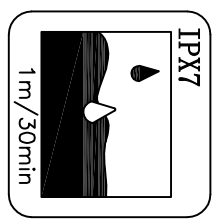
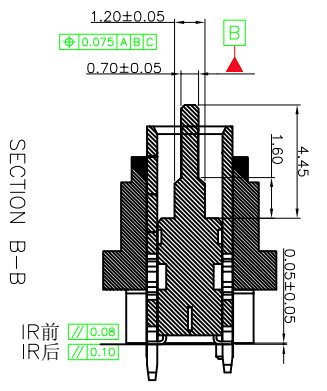
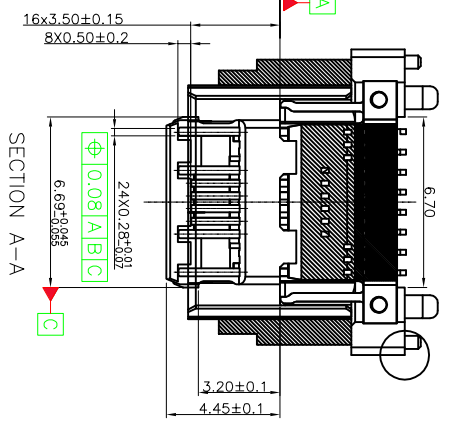
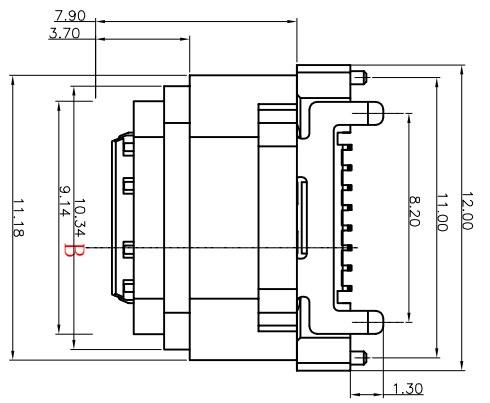

- NOTE:
- MATERIAL:
 - INSULATOR: HIGH TEMPERATURE PLASTIC UL 94 V-0; Black Color
 - CONTACT: C7025 (T=0.12mm)
 - SHELL: STAINLESS STEEL (T=0.40mm)
 - MID PLATE: STAINLESS STEEL (T=0.15mm)
 - ELECTRICAL CHARACTERISTICS:
 - CONTACT RESISTANCE: 40mΩ Max FOR INITIAL. 10mΩ CHANGE AFTER TEST. MEASURE AT 20mV, 100mA.
 - CONTACT CURRENT RATING: 5A FOR COLLECTIVELY POWER SUPPLY PIN(OPTA), A4, A9, A12, B1, B4, B9, B12); 1.25A FOR YCONV PIN. 0.25A FOR OTHER SIGNAL PIN.
 - DIELECTRIC WITHSTANDING VOLTAGE: 100V AC R.M.S.
 - INSULATION RESISTANCE 100MΩ Min
 - OPERATING TEMPERATURE: -40° C ~ 85° C
 - MECHANICAL CHARACTERISTICS:
 - MATING FORCE: 5~20 N.
 - UNMATED FORCE: 8~20N INITIAL. TEST: 6~20N DURABILITY AFTER TEST
 - DURABILITY: 10,000 CYCLES
 - PLATING
 - TERMINAL CONTACT: Au 3μ" PLATING ON CONTACT AREA. TIN 80μ" Min TIN6 ON SOLDER TAIL. NI 60μ" Min UNDERPLATING-OVERALL
 - SHELL: 60μ" Min. NICKEL A.L. OVER.
 - MID PLATE: CLEAN

NO.	DESCRIPTION	MATERIAL	REMARKS	QTY
5	CAP	LCP 6607MS UL94V-0	BLACK	1PCS
4	SHELL	SUS304 T=0.40mm	NI 50μ" Min Plated	1PCS
3	LATCH	SUS301-H T=0.15mm	NO PLATED	1PCS
2	CONTACT	C7025 T=0.12mm	NO PLATING ON CONTACT RESISTANCE MEASUREMENT AREA	1SET
1	HOUSING	LCP UL94V-0	LCP BLACK UL94V-0	1PCS

产品图
PRODUCT CHART DWG
公差一览表
TOLERANCE UNLESS OTHERWISE

深圳市鑫风雷电子有限公司
Shenzhen xinfenglei Electronics Co., Ltd

单位 UNITS	比例 SCALE	日期 DATE	核准 Appd	联系方式 Macthor/Weib	产品料号 PRODUCT PART NO	产品名称 PRODUCT NAME
MM	1:1	2009/10/20	王冠 Wangguan	雷永健 Leiyongjian	19012-UCAP017-X	Type C 18P 180度立式SMD H=4.5 脚长1.38/4.8

THIS DRAWING CONTAINS INFORMATION THAT IS PROPRIETARY TO XINFENGLI ELECTRONIC CO.,LTD AND SHOULD NOT BE USED WITHOUT WRITTEN PERMISSION

ROHS 客户图

目錄 MAPX 40	變更內容 MODIFICATION NEW	日期 DATE 09-10-20
------------------	-----------------------------	------------------------

加防水圈示意图

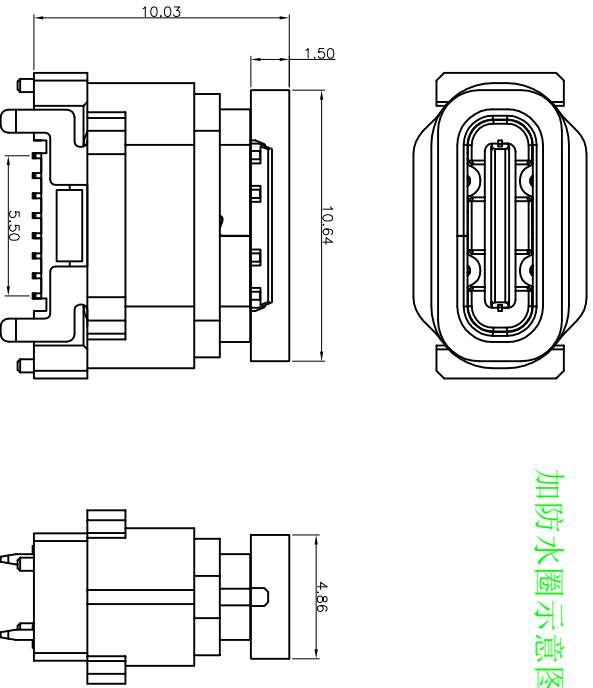

加CAP示意图

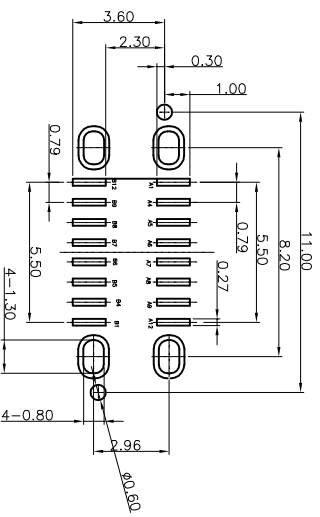
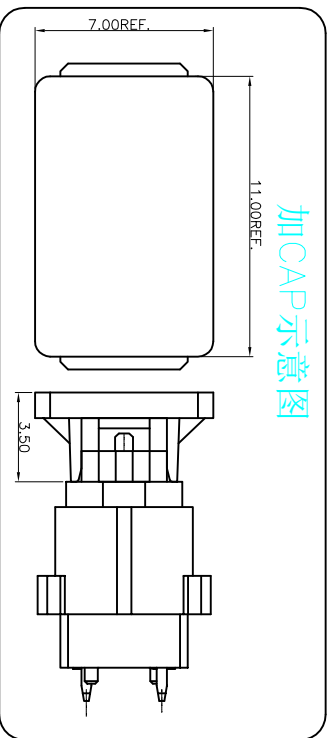

RECOMMENDED P.C.B. LAYOUT (1:1.00mm)
TOLERANCE UNSPECIFIED ±0.05mm

USB TYPE-C FULL-FEATURED RECEPTACLE INTERFACE PIN ASSIGNMENTS

Pin	Signal Name	Description	Pin	Signal Name	Description
A1	DM	Ground return	R12	DM	Ground return
A4	Vbus	Bus Power	B9	Vbus	Bus Power
A5	CC1	Configuration Channel 1	B8	SN2	Shielded (see(SB))
A6		Positive half of the USB 2.0 differential pair-Position 1	B7	D+2	Negative half of the USB 2.0 differential pair-Position 1
A7		Negative half of the USB 2.0 differential pair-Position 1	B6	D-2	Positive half of the USB 2.0 differential pair-Position 2
A8	SN1	Shielded (see(SB))	B5	CC2	Configuration Channel 2
A9	Vbus	Bus Power	B4	Vbus	Bus Power
A12	DM	Ground return	B1	DM	Ground return

产品图

公差一览表
TOLERANCE UNLESS OTHERWISE SPECIFIED

公差	公差	公差	公差
X	±0.30	X'	±5°
X	±0.25	X''	±2°
.XX	±0.20	.XX'	±1°
.XXX	±0.15	.XXX'	±0.5°

深圳市鑫风雷电子有限公司

Shenzhen xinfenglei Electronics Co., Ltd

单位 UNITS	MM	制图 DRAWING	王冠 Wangguang	产品料号 PRODUCT PART NO.	19012-UCAF017-X
比例 SCALE	1:1	审核 CHECK	雷永健 Lei Yongjian	产品名称 PRODUCT NAME	
日期 DATE	2009/10/20	核准 APPROVE	雷永健 Lei Yongjian	联系方式 CONTACT INFO	mailbox: sale@xfli.com.cn www.xfli.com.cn

THIS DRAWING CONTAINS INFORMATION THAT IS PROPRIETARY TO XINFENGLI ELECTRONIC CO.,LTD AND SHOULD NOT BE USED WITHOUT WRITTEN PERMISSION

ROHS 客户图

目錄 MAPX 40	修改內容 MODIFICATION NEW	日期 DATE 09-10-20
------------------	-----------------------------	------------------------

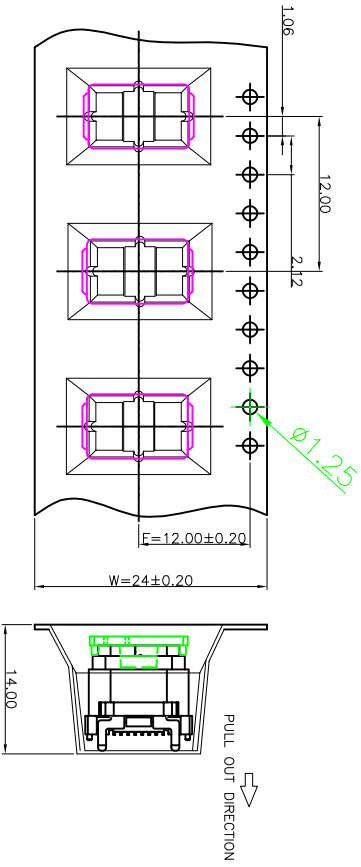
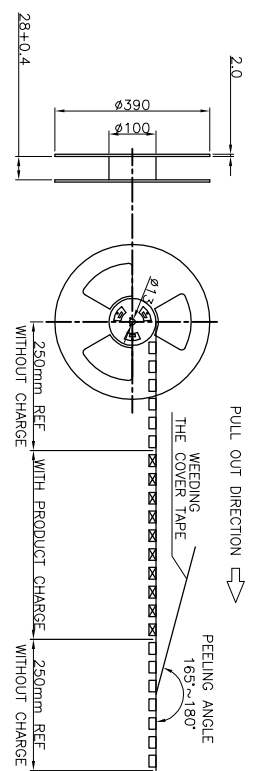

300	10	3000 PCS
PCS/卷	卷/箱	箱

- 注意:
1. 材料:
纸箱: 纤维板, 瓦楞, 双层壁。
胶带: 聚苯乙烯, 耐热温度: 120°C, 白。
卷筒: 聚苯乙烯, 耐热温度: 70°C, 蓝色。
包装: 聚乙烯, 耐热温度: 100°C。
 2. 剥离强度: 0.1 ~ 1.3 N(10 ~ 130克)
 3. 脱皮速度: 300mm / min。
 4. 每个袋子都应包括干燥剂*2。
 5. 外箱上贴号物料标签及RHOS标签
 6. 同一产品只能装同一纸箱, 不允许其它产品;

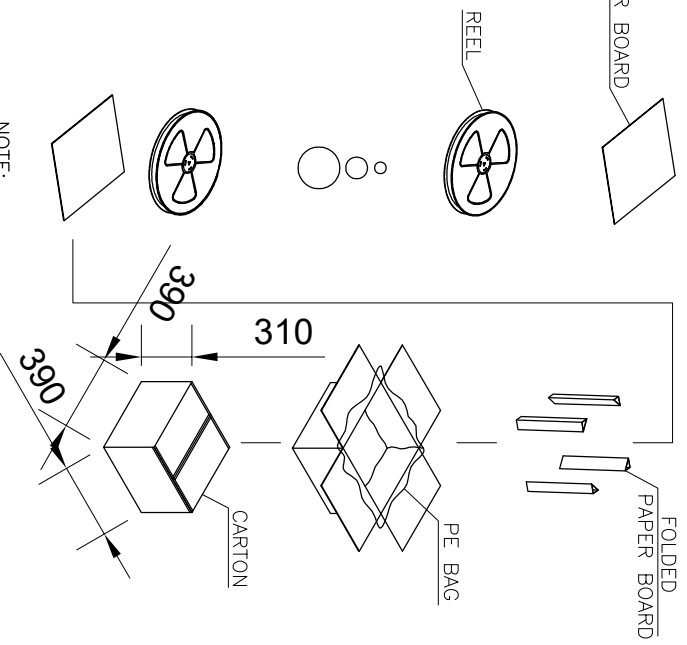

NOTE:
1. QUANTITY: 300 PCS/REEL, 3000PCS/CARTON.

产品图 PRODUCT CHART DWG		深圳市鑫风雷电子有限公司 Shenzhen xinfenglei Electronics Co., Ltd	
公差一览表 TOLERANCE UNLESS OTHERWISE		单位 UNITS	MM
X	±0.30	X	±5°
X	±0.25	X	±2°
.XX	±0.20	.XX	±1°
.XXX	±0.15	.XXX	±0.5°
日期 DATE	2009/10/20	制图 DRAWING	王冠 Wangguang
		审核 CHECK	雷永健 Leiyongjian
		核准 Appd	雷永健 Leiyongjian
		产品料号 PRODUCT PART NO.	19012-UCAF017-X
		产品名称 PRODUCT NO.	Type C 18P 180度立式SMT H-4.5 脚长1.30/外型
		联系方式 Macthor/aveb	mailbox: sale1@xf1.com.com www.xf1.com.com

THIS DRAWING CONTAINS INFORMATION THAT IS PROPRIETARY TO XINFENGLI ELECTRONIC CO.,LTD AND SHOULD NOT BE USED WITHOUT WRITTEN PERMISSION