

ROHS 客户图

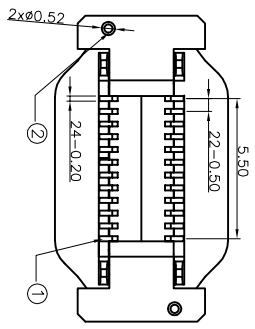
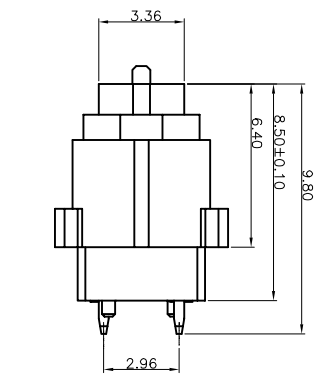
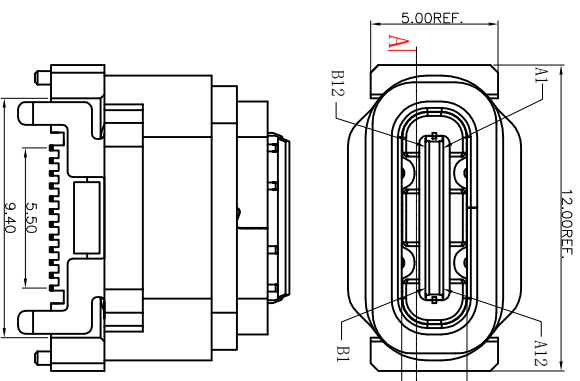
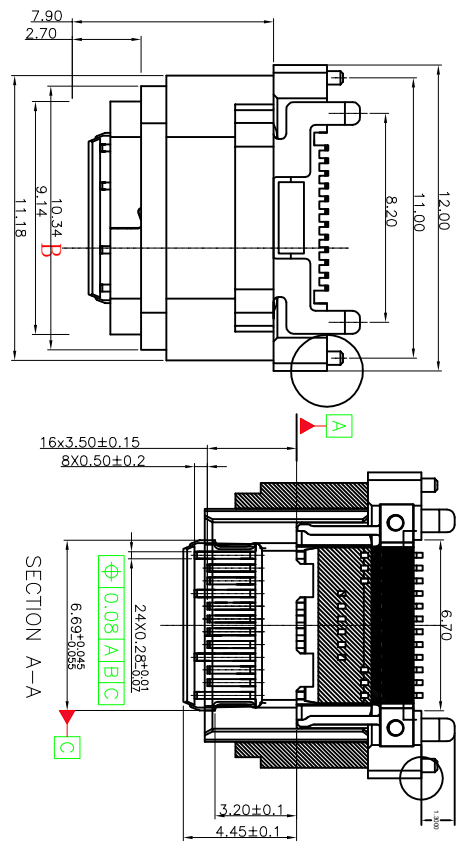

NOTE:
 1. MATERIAL:
 1.1 INSULATOR: HIGH TEMPERATURE PLASTIC UL 94 V-0; Black Color
 1.2 CONTACT: C7025(T=0.12mm)
 1.3 SHELL: STAINLESS STEEL (T=0.30mm)
 1.4 INNER GROUND COVER SHELL: STAINLESS STEEL (T=0.10mm)
 1.5 MID PLATE: STAINLESS STEEL (T=0.15mm)
 2. ELECTRICAL CHARACTERISTICS:
 2.1 CONTACT RESISTANCE: 40mΩ Max FOR INITIAL, 10mΩ CHANGE AFTER TEST. MEASURE AT 20mV, 100mA.
 2.2 CONTACT CURRENT RATING: 5A FOR COLLECTIVELY POWER SUPPLY PIV(P/INA), A4, A9, A12, B1, B4, B9, B12); 1.25A FOR VCONN P.I.N.; 0.25A FOR OTHER SIGNAL P.I.N.
 2.3 DIELECTRIC WITHSTANDING VOLTAGE: 100V AC R.M.S.
 2.4 INSULATION RESISTANCE 100MΩ Min
 2.5 OPERATING TEMPERATURE: -40° C ~ 85° C
 3. MECHANICAL CHARACTERISTICS:
 3.1 MATING FORCE: 5-20 N.
 3.2 UNMATED FORCE: 8-20N INITIAL TEST; 6-20N DURABILITY AFTER TEST
 3.3 DURABILITY: 10,000 CYCLES
 4. PLATING
 4.1 TERMINAL CONTACT: Au 3μ" PLATING ON CONTACT AREA; TIN 50μ" Min TING ON SOLDER TAIL; NI 50μ" Min UNDERPLATING OVERALL
 4.2 SHELL: 50μ" Min. NICKEL ALL OVER.
 4.3 MID PLATE: CLEAN

NO.	DESCRIPTION	MATERIAL	REMARKS	QTY
5	CAP	LCP 6007MS UL94V-0	BLACK	1PCS
4	SHELL	SUS304 T=0.40mm	NI 50μ" Min Plated	1PCS
3	LATCH	SUS304 T=0.15mm	NO PLATED	1PCS
2	CONTACT	C7025 T=0.12mm	NO PLATING ON CONTACT RESISTANCE MEASUREMENT SUS304 PLATING ON OTHER PARTS	1SET
1	HOUSING	LCP UL94V-0	LCP BLACK UL94V-0	1PCS

产品图		公差一览表	
单位	公差	单位	公差
UNITS	TOLERANCE UNLESS OTHERWISE	UNITS	TOLERANCE UNLESS OTHERWISE
MM	±0.30	X"	±5°
MM	±0.25	X"	±2°
MM	±0.20	XX"	±1°
MM	±0.15	XXX"	±0.5°

产品图		Shenzhen xinfenglei Electronics Co., Ltd	
单位	比例	日期	日期
UNITS	SCALE	DATE	DATE
MM	1:1	2009/10/20	

制图	审核	产品料号	产品名称
DRAWING	CHECK	PRODUCT PART NO.	PRODUCT NAME
王冠	雷永健	19012-UCAF019-X	
Wangguan	Leiyongjian		

联系	联系	
方式	方式	
MAILBOX	MAILBOX	
雷永健	雷永健	19012-UCAF019-X
Leiyongjian	Leiyongjian	
www.xf.com	www.xf.com	

目录	变更内容	日期
MAPX	MODIFICATION	DATE
40	NEW	09-10-20

THIS DRAWING CONTAINS INFORMATION THAT IS PROPRIETARY TO XINFENGLI ELECTRONIC CO.,LTD AND SHOULD NOT BE USED WITHOUT WRITTEN PERMISSION

由 Autodesk 教育版产品制作

由 Autodesk 教育版产品制作

ROHS 客户图

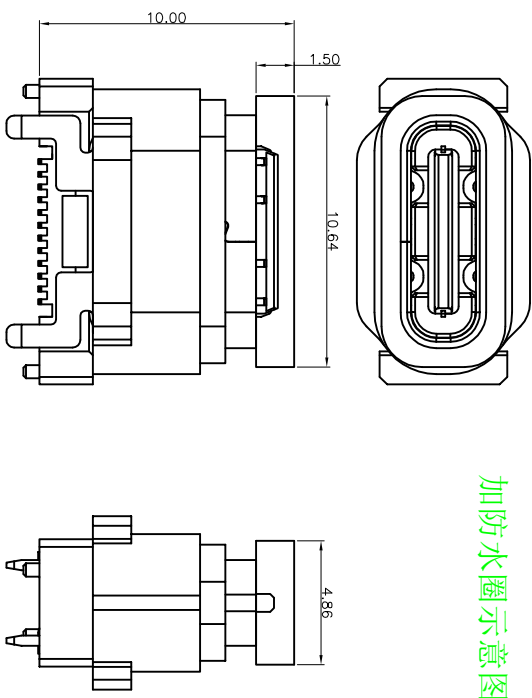

加防水圈示意图

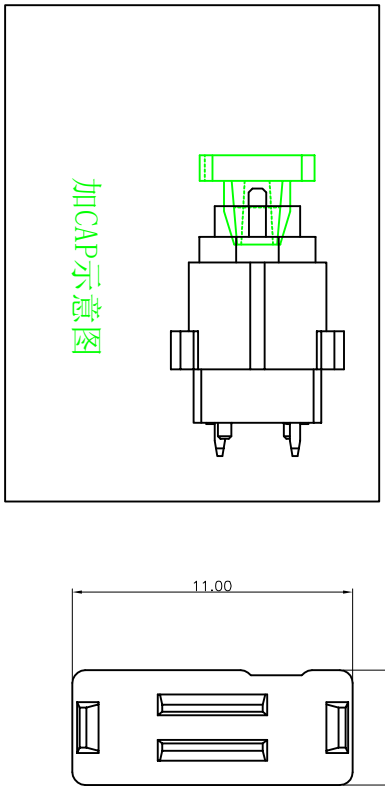

加CAP示意图

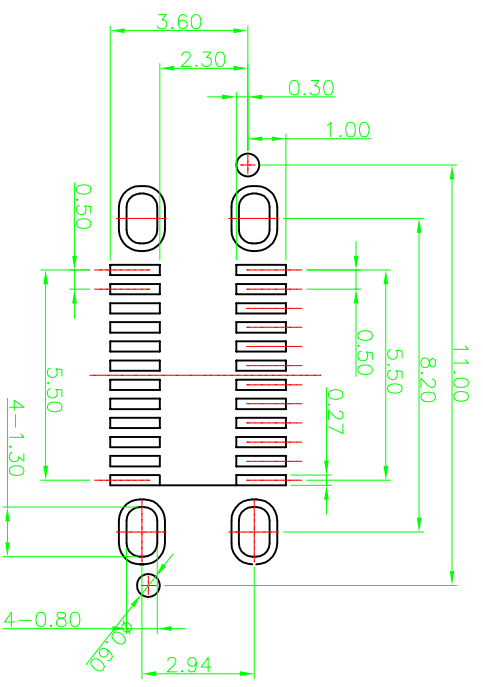

RECOMMENDED P.C.B. LAYOUT (T:1.00mm)
TOLERANCE UNSPECIFIED ±0.05mm

目錄 MAPX 40	變更內容 MODIFICATION NEW	日期 DATE 09-10-20
------------------	-----------------------------	------------------------

USB TYPE-C FULL-FEATURED RECEPTACLE INTERFACE PIN ASSIGNMENTS

Pin Name	Description	Pin Name	Description
A1 GND	Ground return	R12 GND	Ground return
A4 Vcc	Bus Power	B9 Vcc	Bus Power
A5 CC1 Channel 1	Configuration	B8 SBU2 Shielded Iso(SBU)	
A6 [a] Positive half of the USB 2.0 differential pair-Position 1		B7 D+2	USB 2.0 differential Positive half of the pair-Position 2
A6 [b] Negative half of the USB 2.0 differential pair-Position 1		B6 D-2	USB 2.0 differential Negative half of the pair-Position 1
A8 SBU1 Shielded Iso(SBU)		B5 CC2 Channel 2	Configuration
A9 Vcc	Bus Power	B4 Vcc	Bus Power
A12 GND	Ground return	B1 GND	Ground return

产品图 PRODUCT CHART DWG		深圳市鑫风雷电子有限公司 Shenzhen xinfenglei Electronics Co., Ltd	
公差一览表 TOLERANCE UNLESS OTHERWISE		单位 UNITS MM	制图 DRAWING 王冠 Wangguan
X	±0.30	X'	±5°
X	±0.25	X''	±2°
.XX	±0.20	.XX'	±1°
.XXX	±0.15	.XXX'	±0.5°
比例 SCALE	1:1	日期 DATE	2009/10/20
审核 CHECK	雷永健 Leiyongjian	核准 APPD	雷永健 Leiyongjian
产品料号 PRODUCT PART NO.	19012-UCAF019-X	联系方式 Macthor/Weib	www.xf1.com.com
产品名称 PRODUCT NO.			
Type C 2HP 180度立式SMT H=4.5 脚长1.30/4.80		mailbox: sale1@xf1.com.com	
		www.xf1.com.com	

THIS DRAWING CONTAINS INFORMATION THAT IS PROPRIETARY TO XINFENGLI ELECTRONIC CO.,LTD AND SHOULD NOT BE USED WITHOUT WRITTEN PERMISSION

ROHS 客户图

目錄 MAPX 40	修改內容 MODIFICATION NEW	日期 DATE 09-10-20
------------------	-----------------------------	------------------------

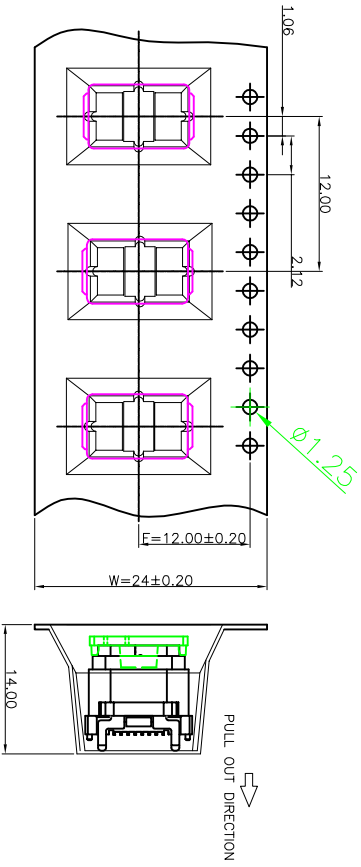
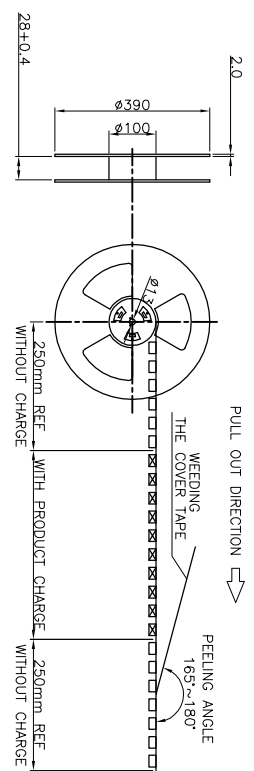

300	10	3000 PCS
PCS/卷	卷/箱	箱

- 注意:
1. 材料:
纸箱: 纤维板, 瓦楞, 双层壁。
胶带: 聚苯乙烯, 耐热温度: 120°C, 白。
卷筒: 聚苯乙烯, 耐热温度: 70°C, 蓝色。
包装: 聚乙烯, 耐热温度: 100°C。
 2. 剥离强度: 0.1 ~ 1.3 N(10 ~ 130克)
 3. 脱皮速度: 300mm / min。
 4. 每个袋子都应包括干燥剂*2。
 5. 外箱上贴号物料标签及RHOS标签
 6. 同一产品只能装同一纸箱, 不允许其它产品;

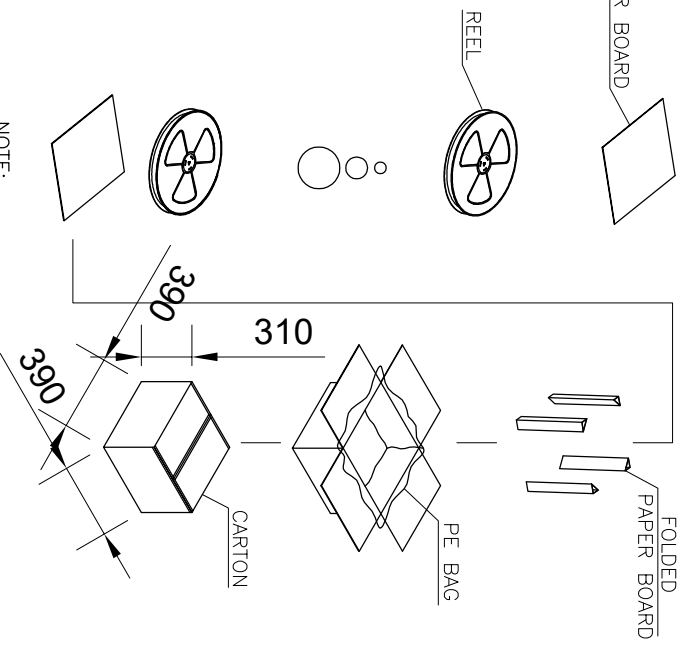

NOTE:
1. QUANTITY: 300 PCS/REEL, 3000PCS/CARTON.

产品图		公差一览表		单位		制图		产品料号	
PRODUCT CHART DWG		TOLERANCE UNLESS OTHERWISE		UNITS		DRAWING		PRODUCT PART NO.	
X	±0.30	X	±5°	比例	1:1	审核	王永健	19012-UCAF019-X	
XX	±0.25	X	±2°	日期	2009/10/20	核准	雷永健		
XXX	±0.15	XX	±1°	日期	2009/10/20	核准	雷永健		
		XXX	±0.5°	日期		核准	雷永健		

深圳市鑫风雷电子有限公司
Shenzhen xinfenglei Electronics Co., Ltd

联系方式
mail:box: sale1@xf1.com.com
www: xf1.com.com

THIS DRAWING CONTAINS INFORMATION THAT IS PROPRIETARY TO XINFENGLI ELECTRONIC CO.,LTD AND SHOULD NOT BE USED WITHOUT WRITTEN PERMISSION