

RoHS 客户图

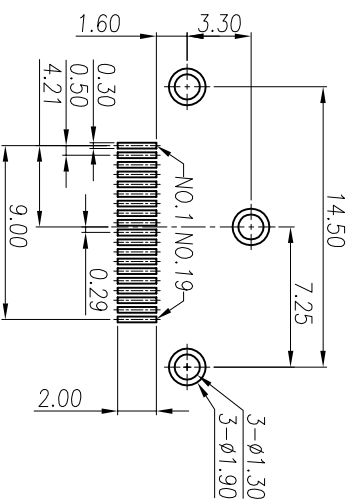
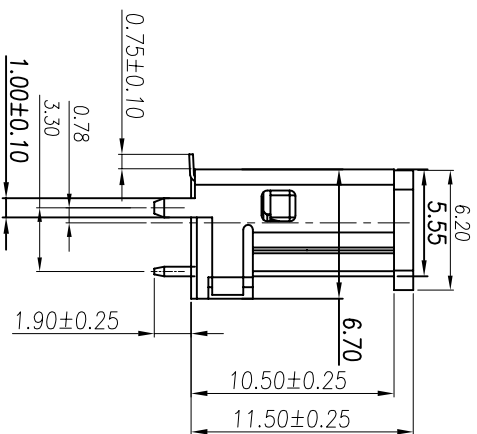
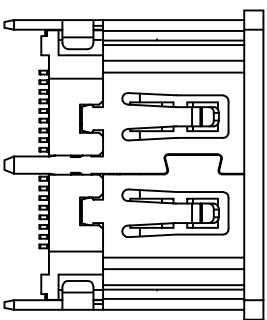
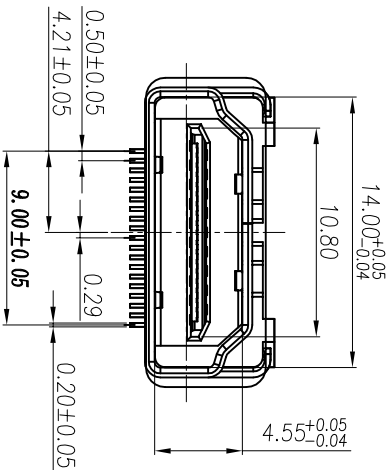

RECOMMENDED P.C.B. LAYOUT(T=1.6mm)
TOLERANCES UNLESS OTHERWISE SPEC.±0.05

NOTES:

- 1.) MATERIAL:
 - 1-1. HOUSING AND COVER: LCP, UL 94V-0, COLOR: BLACK; HF
 - 1-2. CONTACT: BRASS T=0.20;
 - 1-3. SHELL: BRASS T=0.50;
 - 1-4. CAP: LCP BLACK UL 94-V0
- 2.) FINISH:
 - 2-1. CONTACT: Au PLATING ON CONTACT AREA, (SEE P/N DESCRIBING) AU G/F PLATING ON SOLDER TAILS, 50u" MIN. Ni UNDERPLATING OVERALL;
 - 2-2. SHELL: PLATING Ni 50u" MIN.
- 3.) SPECIFICATIONS:
 - 3-1. VOLTAGE RATING: 40V
 - 3-2. CURRENT RATING: 0.5A
 - 3-3. INSULATION RESISTANCE: 100MEG-OHM MIN
 - 3-4. CONTACT RESISTANCE: 30 MILL-OHM MAX
 - 3-5. OPERATION TEMPERATURE: -20° TO +85°
 - 3-6. INSERT FORCE: 44.1N MAX
 - 3-7. EXTRACT FORCE: 9.8N MIN
 - 3-8. DURABILITY: 10000 CYCLES

目録 MAPX	设计内容 MODIFICATION	日期 DATE
A0	NEW	09-10-20

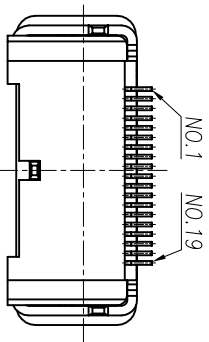

产品图

PRODUCT CHART DWG

公差一览表

TOLERANCE UNLESS OTHERWISE	公差一览表	单位 UNITS	比例 SCALE	日期 DATE	制图 DRAWING	审核 CHECK	核准 APPRO	产品料号 PRODUCT PART NO.	产品名称 PRODUCT NO.	HDMI A TYPE 19P母座 180度SMT H=10.5
X	±0.30	X'	±5'		王冠 Wangguan	雷永健 Leiyongjian	雷永健 Leiyongjian	26022-HDAF011-X		
X	±0.25	X'	±2'		雷永健 Leiyongjian	雷永健 Leiyongjian	雷永健 Leiyongjian			
XX	±0.20	XX'	±1'							
XXX	±0.15	XXX'	±0.5'							

深圳市鑫风雷电子有限公司
Shenzhen xinfenglei Electronics Co., Ltd

联系邮箱: sale1@xfll.com
www.xfll.com.com