

RoHS 客户图

目錄 MAPX	变更内容 MODIFICATION	日期 DATE
A0	NEW	09-10-20

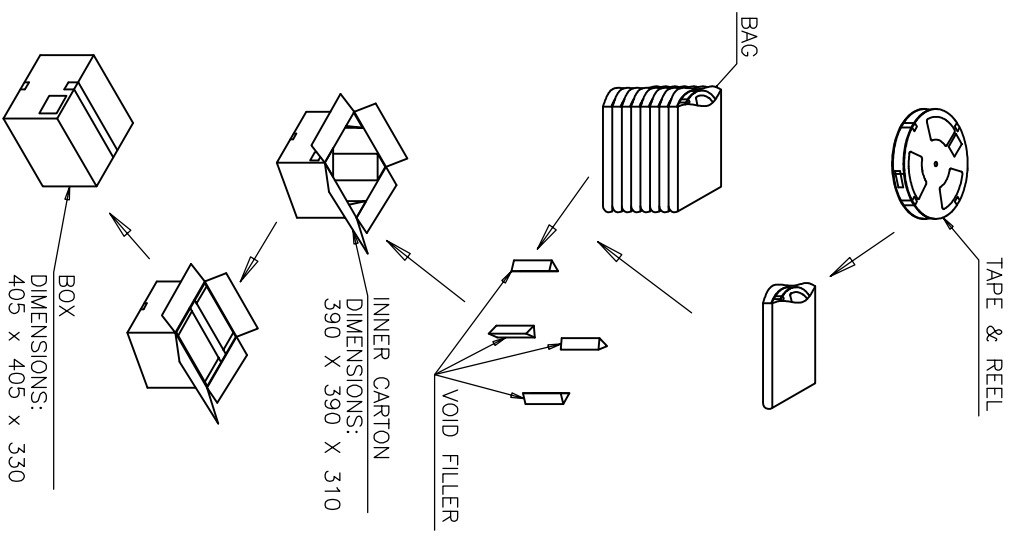
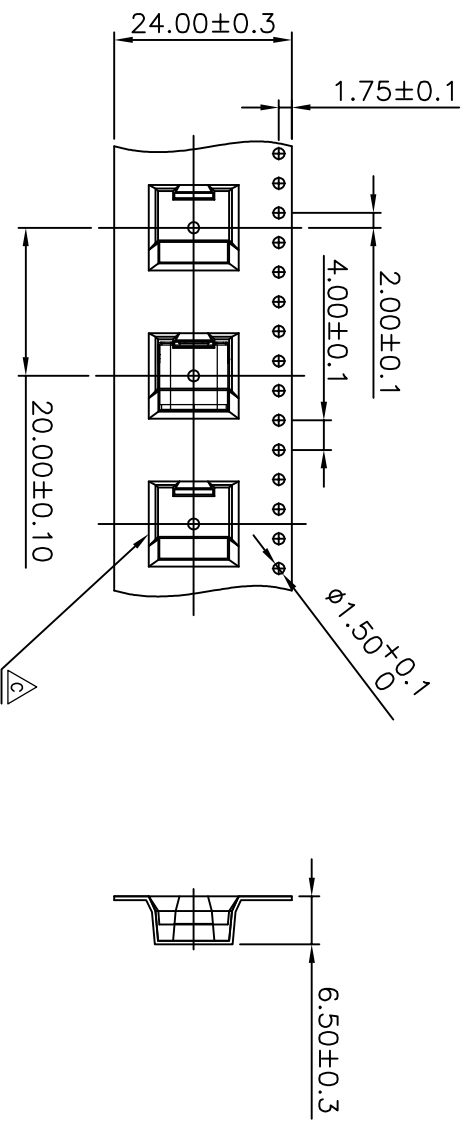
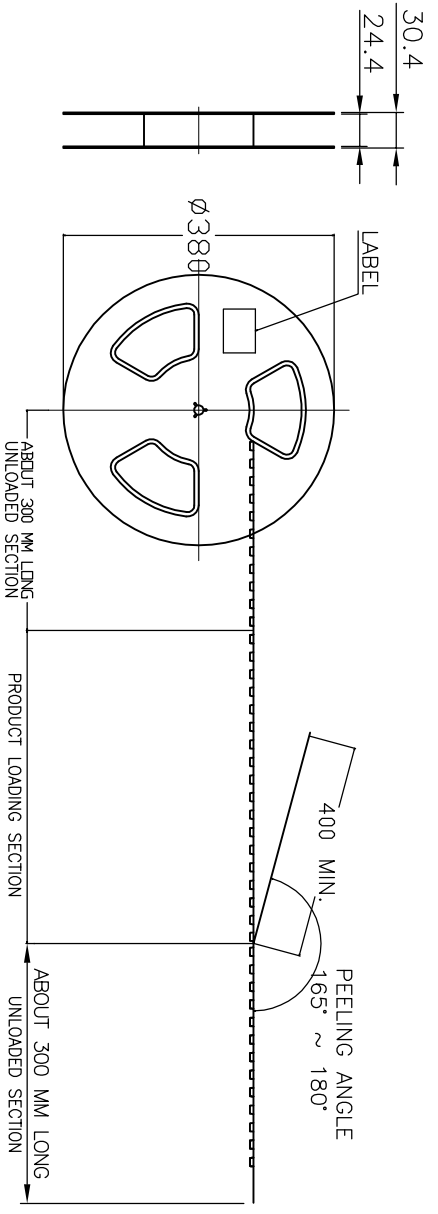

- NOTE:
- MATERIAL:
BOX: FIBREBOARD, CORRUGATED, DOUBLE WALL.
TAPE: POLYSTYRENES, HEAT-RESISTANT TEMPERATURE: 120°C, BLACK COLOR.
REEL: POLYSTYRENES, HEAT-RESISTANT TEMPERATURE: 70°C, BLUE COLOR.
BAG: POLYETHYLENE, HEAT-RESISTANT TEMPERATURE: 100°C.
 - PEELING STRENGTH: 0.1 ~ 1.3 N (10 ~ 130 GRAMS)
 - PEELING SPEED: 300 mm/min.
 - EACH BAG SHALL BE INCLUDED DESICCANT.

产品图 PRODUCT CHART DWG		公差一览表 TOLERANCE UNLESS OTHERWISE	
X	±0.30	X	±5°
X	±0.25	X	±2°
XX	±0.20	XX	±1°
XXX	±0.15	XXX	±0.5°

单位 UNITS	MM	制图 DRAWING	王冠 Wangguan	产品料号 PRODUCT PART NO.	12020-UCAP001-X
比例 SCALE	1:1	审核 CHKD	雷永健 Lei Yongjian	产品名称 PRODUCT NO.	TYPE C 24P FEMALE CJ2.20 H3.91
日期 DATE	2009/10/20	核准 APPD	雷永健 Lei Yongjian	联系方式 CONTACT	mail:box@sale1@fll.com.com www.xfll.com.com

750	10	7500 PCS	-- KG	-- KG
POS/ REEL	CARTON	QUANTITY	GROSS WEIGHT	NET WEIGHT

深圳市鑫风雷电子有限公司
Shenzhen xinfenglei Electronic Co., Ltd